

**Design
for a better
*future /***

Rohrig Constructions

**William Clarke College:
Construction
Environmental
Management Plan**

August 2024

wsp

Question today Imagine tomorrow Create for the future

William Clarke College: Construction Environmental Management Plan

Rohrig Constructions

WSP

Level 3, 51-55 Bolton St

Newcastle NSW 2300

PO Box 1162



Newcastle NSW 2300

Tel: +61 2 4929 8300

Fax: +61 2 4929 8382

wsp.com

REV	DATE	DETAILS
Draft	30 August 2023	Draft for internal and client review
0	6 th September 2023	Issue

	NAME	DATE	SIGNATURE
Prepared by:	Stuart Longman	28 August 2024	
Reviewed by:	Louise MacDonald	30/8/24	
Approved by:	Nick Savas (Rohrig)		

WSP acknowledges that every project we work on takes place on First Peoples lands.
We recognise Aboriginal and Torres Strait Islander Peoples as the first scientists and engineers and pay our respects to Elders past and present.

This document may contain confidential and legally privileged information, neither of which are intended to be waived, and must be used only for its intended purpose. Any unauthorised copying, dissemination or use in any form or by any means other than by the addressee, is strictly prohibited. If you have received this document in error or by any means other than as authorised addressee, please notify us immediately and we will arrange for its return to us.

March 2023

Table of contents

1	Introduction	1
1.1	Project description	1
1.2	Project scope	1
1.3	Project location.....	2
1.4	Purpose of the CEMP	2
1.5	CEMP approval	3
2	Planning and Approvals	4
2.1	Project Approval.....	4
2.2	Environmental Impact Statement	4
3	Project requirements.....	5
3.1	Construction scope	5
3.2	Construction timing	5
3.2.1	CEMP approval.....	5
3.2.2	Timing of works.....	5
3.2.3	Duration of works.....	5
3.2.4	Hours of work	5
3.2.5	Deliveries and traffic restrictions	6
3.2.6	Parking restrictions	6
3.2.7	Pedestrian restrictions	6
3.2.8	High impact noise works timing restrictions	6
4	Communication	7
4.1	Notification of commencement.....	7
4.2	Community communication	7
4.3	Induction.....	7
4.4	Project Contacts	8
4.5	Roles and responsibilities	8
4.6	Toolbox talks/pre-starts.....	10
4.7	Site monitoring and record keeping.....	10
4.7.1	Site Inspection Checklist.....	10
4.7.2	Project Mangers Inspection Checklist.....	10
4.7.3	Site Monitoring Schedule	11
4.8	Complaints	11
4.9	Auditing	11

5	Site setup	12
5.1.1	Site layout.....	12
5.1.2	Project site hoarding	12
5.1.3	Project site fencing	12
5.1.4	Project site signage	13
5.1.5	Housekeeping / project site amenity	13
5.1.6	Site vehicles	13
5.1.7	Driver code of conduct.....	13
5.1.8	Avoiding obstruction to the public	14
6	Environmental framework	15
6.1	Environmental Policy	15
6.2	Environmental Management System.....	16
6.3	Project environmental expectations.....	17
6.4	General Responsibilities.....	17
7	Project environmental management.....	18
7.1	Outdoor Lighting	18
7.2	Plant and equipment	18
7.3	Refuelling	18
7.4	Spill mitigation	18
7.5	Chemical storage and handling	18
7.6	Traffic management and project site access.....	19
7.7	Construction noise and vibration	19
7.8	Erosion and sediment control.....	19
7.9	Dust mitigation	20
7.10	Heritage	20
7.11	Vegetation protection.....	20
7.12	Waste management.....	21
7.12.1	Waste streams.....	21
7.12.2	Disposal contractors	22
7.13	Imported materials	22
7.14	Contamination	22
8	Contingency Plans	23
8.1	Environmental Incidents.....	23
8.1.1	Incident response and investigation.....	23

8.1.2	Spill management and response	24
8.1.3	Incident notification to NSW Planning Secretary	24
8.1.4	EPA Reporting	25
8.2	Unexpected Finds Protocols	25
8.2.1	Unexpected finds – Aboriginal heritage	25
8.2.2	Unexpected finds – skeletal remains	25
8.2.3	Unexpected Finds Protocol – Historic Heritage	26
8.2.4	Unexpected finds - contamination.....	26
8.2.5	Wet weather	26
8.2.6	Flood management.....	26
8.3	CEMP Review and update.....	27
8.4	Audit.....	27
9	Limitations	28
9.1	Permitted purpose	28
9.2	Qualifications and assumptions	28
9.3	Use and reliance	28
9.4	Disclaimer	29

List of Appendices

- 1 Noise and Vibration Management Plan
- 2 Traffic Management Plan
- 3 Erosion and Sediment Control plan
- 4 Community Engagement Strategy
- 5 Emergency Management Plan
- 6 Site layout
- 7 EMP Checklists

1 Introduction

1.1 Project description

The proposed construction works involves the construction of Stage 1 works at William Clarke College in Kellyville NSW. This stage of work is part of an approved masterplan for the school to meet the demands of the growing local community.

Stage 1 works have been approved by the Minister for Planning and Public Spaces (NSW) under section 4.38 of the Environmental Planning and Assessment Act (1979).

Rohrig will be undertaking the construction of the Bryson building as part of these approved stage 1 works.

1.2 Project scope

Stage 1 construction works include:

- Site preparation, including tree removal, bulk earthworks and civil works for the Bryson Building
- Construction of the Bryson Building for use as classrooms, staff rooms, library and ancillary teaching spaces, to be located in the centre of the site
- Landscaping ancillary to Bryson Building including tree planting.

Figure 1-1 William Clarke College Masterplan (Extract from EIS) – Stage 1 outlined in red

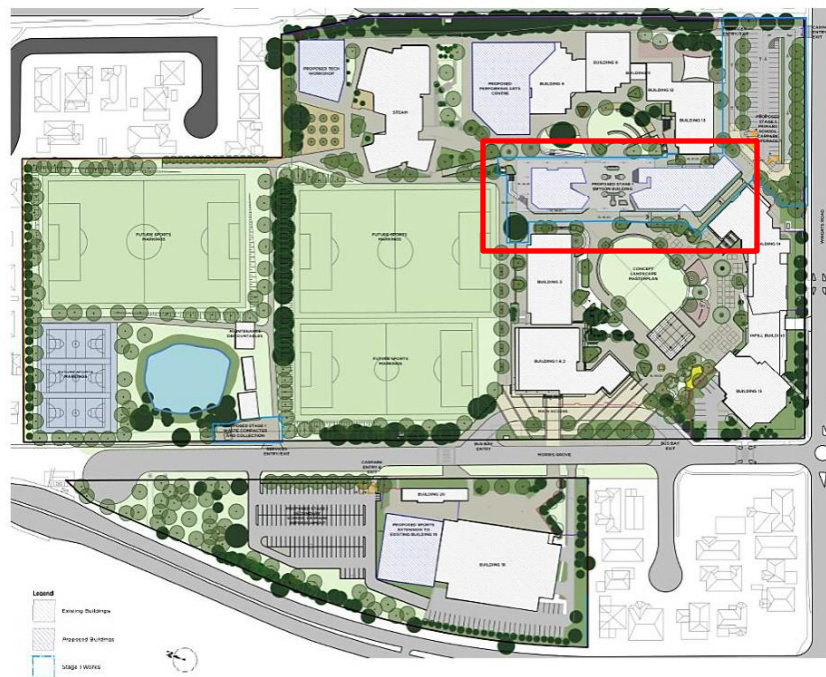

1.3 Project location

The project site is within a school: William Clarke College, located at 10 Morris Grove, Kellyville NSW and is legally described as Lot 10 in DP 1169003.

Figure 1-2 location of William Clarke College in Kellyville NSW (Source EIS 2022)



1.4 Purpose of the CEMP

The purpose of the Construction Environmental Management Plan (CEMP) is to meet the criteria as defined within the approved State Significant Development (SSD-35715221). As per Schedule 3 Part C of the conditions of consent, clause C14 states the requirement for preparation of a Construction Environmental Management Plan (CEMP) as per below.

The CEMP must be generally consistent with the document construction management plan dated 26 September 2022 prepared by Rohrig and include, but not be limited to:

(a) construction details:

(i) hours of work

(ii) 24-hour contact details of site manager

(iii) management of dust and odour to protect the amenity of the neighbourhood;

(iv) groundwater management plan including measures to prevent groundwater contamination

(v) External lighting in compliance with as 4282-2019 control of the obtrusive effects of outdoor lighting

(vi) community consultation and complaints handling as set out in the community communication strategy required by schedule 3 condition c8

(vii) detail the quantities of each waste type generated during construction and the proposed reuse, recycling and disposal locations; and

(viii) flood emergency procedures during construction works

- (b) construction traffic and pedestrian management sub-plan (as per schedule 3 condition c16)*
- (c) construction noise and vibration management sub-plan (as per schedule 3 condition c17)*
- (d) construction soil and water management sub-plan (as per schedule 3 condition c18)*
- (e) an unexpected finds protocol for contamination and associated communications procedure*
- (f) an unexpected finds protocol for aboriginal and non-aboriginal heritage and associated communications procedure*
- (g) waste classification (for materials to be removed) and validation (for materials to remain) be undertaken to confirm the contamination status in these areas of the site.*

An Environmental Impact Statement (EIS) was prepared for this project DFP Planning Pty Ltd (24th October 2022). The EIS and subsequent submission report identified environmental aspects and impacts and specified mitigation measures have been included in this CEMP.

The purpose of this CEMP is to detail the specific measures to be implemented during the construction phase of this project in order to manage and mitigate environmental risk.

This CEMP has been prepared in accordance with the requirements as set out in the project Development Consent, the approved EIS and *Environmental Management Plan Guideline for Infrastructure Projects* (NSW Planning Portal, April 2020).

This CEMP has been prepared in line with the Rohrig Construction management plan dated 26 September 2022.

1.5 CEMP approval

The project construction works must not commence until the CEMP is approved by the Certifier and a copy submitted to the Planning Secretary.

2 Planning and Approvals

2.1 Project Approval

This project has been approved via Development Consent (SSD-35715221) under Section 4.38 of the Environmental Planning and Assessment Act 1979 by the NSW Minister for Planning and Public Spaces. The conditions of consent as have been incorporated into this CEMP and associated sub plans and must be adhered to during construction of this project.

Refer to **Error! Reference source not found.** for detail on where the relevant conditions of consent (construction phase) are addressed in this CEMP.

2.2 Environmental Impact Statement

An EIS was prepared by DFP Planning Consultants (12th October 2022) for the development to fully assess possible all matters affecting or likely to affect the environment during construction and specifies required mitigation measures. The mitigation measures have been updated during the responses to submission and have been incorporated into the Amended Mitigation Measures (for SSD-35715221) prepared by DPF Planning Consultants (June 2023).

The amended mitigation measures have been incorporated into this CEMP and associate sub plans and must be complied with during construction of this project.

3 Project requirements

3.1 Construction scope

The works can be summarised as the below phases of construction

- 8 Site establishment and preliminary works
 - a Site hoarding, access, signage and fencing and temporary car parking
 - b Environmental controls installation
- 9 Bryson Building construction
 - a Vegetation works clearing, stripping and stockpile
 - b Groundworks and construction of new building
 - c Construction of footings and slab (north and south)
 - d Structural concrete and steel works
 - e Cladding and roofing of new building
 - f External works to the main building concurrent with
 - g Internal building services and fit out
 - h Defects rectification and commissioning
 - i Completion works and disestablishment

3.2 Construction timing

3.2.1 *CEMP approval*

The project construction works must not commence until the CEMP is approved by the Certifier and a copy submitted to the Planning Secretary.

3.2.2 *Timing of works*

The works are proposed to commence in mid-September 2024.

The works will be co-ordinated with the school throughout construction to reduce impacts on the school timetable and any significant events that will be hosted by the school.

Bell times will remain unchanged unless determined by the school.

3.2.3 *Duration of works*

Construction of the Bryson Building is expected to take 14-16 months with completion estimated at late 2025.

3.2.4 *Hours of work*

Construction including deliveries of materials to and from the site may only be carried out between the following hours:

- 7am and 6pm, Mondays to Fridays
- 8am to 1pm on Saturdays.
- No work may be carried out on Sundays or public holidays

3.2.4.1 Out of hours work

Construction activities may only be undertaken outside of the hours specified above if:

- Required by the Police or a public authority for the delivery of vehicles, plant or materials
- It is an emergency to avoid the loss of life, damage to property or to prevent environmental harm
- The works are inaudible at the nearest sensitive receivers
- A variation is approved in advance in writing by the Planning Secretary if suitable justification is provided

3.2.5 *Deliveries and traffic restrictions*

In order to minimise the possibility of conflict with parents and students during school drop-off and pickup times, construction vehicle access will be restricted during school terms at the following times.

- 7:45am – 8:45am Monday – Friday
- 2:45pm – 3:45pm Monday – Friday

Refer to the project specific Traffic management plan include in Appendix B of this CEMP for further detail.

3.2.6 *Parking restrictions*

Refer to the project specific Traffic management plan included in Appendix B of this CEMP for details.

3.2.7 *Pedestrian restrictions*

Refer to the project specific Traffic management plan included in Appendix B of this CEMP for details.

3.2.8 *High impact noise works timing restrictions*

Refer to the project specific Noise and vibration management plan included in Appendix A of this CEMP for details.

Rock breaking, rock hammering, sheet piling, pile driving, and similar high impact noisy activities is to be minimised where feasible. The development consent indicates that these noisy activities may only be carried out between the following hours:

- 9am to 12pm, Monday to Friday
- 2pm to 5pm Monday to Friday
- 9am to 12pm, Saturday.

The works will be co-ordinated with the school to reduce noise impacts on the school operations throughout the project.

4 Communication

4.1 Notification of commencement

At least 48 hours prior to commencement of construction works, the Planning Secretary is to be notified in writing of the date of the intended commencement of construction.

Additionally, the Planning Secretary is to be notified in writing at least 48 hours before the commencement of each stage of works, of the date of commencement and the development to be carried out in that stage.

4.2 Community communication

At least 2 weeks prior to commencement of construction a Community Communication Strategy is to be submitted to the Planning Secretary for information. Refer to Appendix D of this CEMP for details.

The Community Communication Strategy details how communication will occur between the Rohrig and affected stakeholders including:

- Council
- The school community
- Affected residential neighbours, businesses and sensitive receivers

This communication is required before and during construction of the project and for a minimum of 12 months following the completion of construction.

This strategy:

- Identifies who is to be notified and consulted during the construction phases
- Sets out procedures for the regular distribution of information about the construction works
- Sets out procedures through which the community can enquire or provide feedback to Rohrig
- Sets out how Rohrig will respond to enquiries or feedback from the community
- Identifies how issues and complaints will be managed and resolved in relation to construction

Communication to stakeholders will include any specific traffic, parking, pedestrian, noise and vibration, visual amenity, or other environmental aspects of the construction.

4.3 Induction

Prior to undertaking any work at the project site, all employees and subcontractors will attend an induction session which will incorporate training on the procedures and controls measures associated with this plan.

The induction process for all employees and subcontractors will include a section on environmental awareness, and cover as a minimum:

- Company Environment Policy
- General environmental responsibilities and project site expectations
- Site emergency response

- Limits of clearing and NO-GO areas
- Waste management and minimisation requirements
- Hazardous materials storage / handling
- Refuelling procedures and spill response
- Access to the project site and vehicle access restrictions/requirements for parking
- Timing restrictions for deliveries
- Site specific environmental controls
- Dust and emissions mitigation requirements
- Noise and vibration requirements
- Hours of work and rules on working in a school environment
- Complaints handling
- Unexpected finds and emergency procedure
- Locations of project office, lunchrooms, change rooms, ablutions, spill kit and first aid

4.4 Project Contacts

The key project contacts for all environmental matters are included below table

Role	Contact name	Contact detail
General Manager (Rohrig office)	David Campbell	02 9695 1668
Project Manager	Brad Blanshard	0435 755 307
Site manager	Andries van der Walt	0437 017 720

4.5 Roles and responsibilities

Rohrig will have overall responsibility for implementing and managing this CEMP. All on-site personnel (employees and sub-contractors) must adhere to the requirements of this plan. Key personnel and associated responsibilities for this project are presented in Table 4-1

Table 4-1 Roles and responsibilities

Personnel	Roles and responsibility
Rohrig Director	<p>The Director has overall responsibility for safety for the company and for management of the health and safety for Rohrig personnel. Specific WHSE responsibilities include:</p> <ul style="list-style-type: none"> — Ensuring compliance with the requirements of the Work Health and Safety Legislation (WH&S Act 2011 and WH&S Regulations 2011), Environmental legislation, relevant Codes of Practice, standards including Australian Standards, and Industry best practice.

	<ul style="list-style-type: none"> — Implementation of the company’s Health, Safety and Environmental Policy and Procedures. — Assigning safety and environmental responsibilities to nominated personnel of Rohrig — Ensuring adequate and sufficient resources are provided to implement the health, safety and environmental management system. Resources may include physical, technical and financial. — Supporting project/workplace personnel to implement the health, safety and environmental management system. — Regularly reviewing the company’s health, safety and environmental management system for improvement opportunities. — Initiating external audits and reviews of the Rohrig ’ s health, safety and environmental management system. — Ensuring appropriate health, safety, environmental and technical training is provided where required that will enable personnel to work in a safe, healthy and productive way. — Actively participate in operational and management meetings while promoting health, safety and environmental sustainability as a priority.
Project manager	<p>This position is responsible for environmental management for the project including implementation of this management plan and:</p> <ul style="list-style-type: none"> — Application of the Hierarchy of Risk Controls to eliminate, or if elimination is not practicable, to minimise risks in all design, procurement, manufacturing, fabrication, construction, administration and associated activities — Communication with stakeholders to minimise risks. — Determination of requirements for and implementation of training and education activities. — Promotion of best practices through leadership and example. — Provision and maintenance of safe and environmentally friendly plant, equipment and substances. <p>Review of reports and inspections, and implementation of recommendations.</p> <ul style="list-style-type: none"> — Coordination of incident investigations and reporting to relevant persons and authorities. — Coordination of WHSE meetings and programmes. — Overall responsibility for environmental management on the project site. — Responsibility for management and compliance of all working on-site.
Site supervisor	<p>This position is responsible for environmental management implementation for this project and the implementation of this management plan. As well as:</p> <ul style="list-style-type: none"> — Observation of and adherence to all rules and regulations. — Ensuring that all work activities are carried out in a manner which is healthy, safe, and environmentally sound.

	<ul style="list-style-type: none"> — Planning to carry out all work safely, taking into account any interfacing with other work activities. — Determination of requirements for and implementation of training activities within the Rohrig workforce. — Conducting of workplace inspections and actioning of reports. — Participating in meetings and programmed training. — Investigation of hazard reports, and implementation of corrective actions. — Conduct workplace inductions, toolbox meetings, and team meetings (including pre-start meetings). — Participation in incident investigations. — Promotion of good practices through leadership and example at every opportunity. — Conduct inspections of workplaces to ensure that control measures are implemented and effective, and — Conduct of other duties as directed by the Operations Manager. Ensure this plan is implemented, complied with and updated as necessary.
All personnel (including sub-contractors)	<ul style="list-style-type: none"> — Comply with the requirements of this plan and all site rules. — Responsible for conducting all operations and activities in accordance with this plan. — Report all environmental hazards, near misses and incidents to the site manager or Project Environmental Representative. — Attend inductions and all relevant training.

4.6 Toolbox talks/pre-starts

Further to site inductions, regular toolbox meetings will be held to highlight the activities occurring during that day including a briefing on potential environmental issues (such as odour, noise or dust generating activities) and the control measures in place to mitigate off-site impacts.

4.7 Site monitoring and record keeping

The site will be regularly inspected and assessed to ensure compliance with this CEMP.

4.7.1 *Site Inspection Checklist*

The Rohrig Site Inspection Checklist is a checklist completed by project team members to assess the Health, Safety & environmental condition of the site.

4.7.2 *Project Managers Inspection Checklist*

The Rohrig Project Managers Inspection Checklist has been developed to monitor the physical conditions on-site and intended to be done by the Project Manager from the site. This Assessment will be conducted within a month of the job starting on site, then monthly throughout the duration of the project.

4.7.3 Site Monitoring Schedule

Rohrig Site Inspection Checklist to be undertaken as a minimum Weekly by the site manager.

Rohrig Project Mangers Inspection Checklist to be undertaken as a minimum Monthly by the project manager.

These inspections will be undertaken to ensure all environmental controls are maintained and functional and to maintain a record of environmental management.

4.7.3.1 Other monitoring

Other monitoring and record keeping will include:

- Refuelling.
- Deliveries of materials and source
- Waste generated and recycling/disposal volumes and locations – via waste register.
- Any issues identified e.g. dust, noise, and implemented mitigation measures.
- Complaints or enquiries
- Incidents

Any further action required to mitigate issues identified should be communicated to the Project Manager and plans updated to mitigate issues.

4.8 Complaints

For effective complaint resolution, the following information is required as a minimum:

- Complainants contact details.
- Date, time and location of the complaint.
- Description of complaint.
- The requested remedy/action.
- Immediate action, if required.
- Notification of the complaint and response measures to be issued to all employees and sub-contractors via communal notice board and outlined in following weeks' toolbox meeting to raise awareness.

All complaints are to be referred to the Project Manager for management of rectifications/outcomes.

Incidents and complaints are to be recorded via the Rohrig Procore system.

4.9 Auditing

Audits (both internal and external) may be undertaken during this project by Rohrig (or its representatives) to assess the effectiveness of environmental controls, compliance with this sub plan and other relevant approvals, licences and guidelines.

5 Site setup

5.1.1 Site layout

Figure 5-1 Site layout - Construction



Refer to site layout plan in Appendix F for further detail on site setup and access.

5.1.2 Project site hoarding

The following hoarding requirements must be complied with:

- No third-party advertising is permitted to be displayed on the subject hoarding/ fencing
- The Site Supervisor must be responsible for the removal of all graffiti from any construction hoardings or the like within the construction area within 48 hours of its application.

5.1.3 Project site fencing

Protective fencing is to be installed around the works area to prevent the public/staff and student access to the site. Students/staff or any unauthorised person are not permitted within the project site.

All fencing shall be securely installed, and fence panels have adequate bracing where required.

Fencing is to be maintained and checked regularly during construction to ensure there is no safety risk to school students.

5.1.4 Project site signage

Site signage must be prominently displayed at the access point(s) and at visible public locations along the boundary of the site during construction for the purposes of informing the public of project details.

Signage is to:

- Have minimum dimensions of 841 mm x 594 mm (A1) with any text on the sign to be a minimum of 30-point type size
- Be mounted at eye level on the perimeter hoardings/fencing so that people can read it
- Be durable and weatherproof and must be displayed throughout the works period
- Have information on:
 - The approved hours of work, and how long the construction is expected to take
 - The name of the builder, Certifier, structural engineer, site/ project manager
 - The company name (Rohrig), address and 24-hour contact phone number for site issues
 - Detail on how to make any project enquiries, or complaints.
- State that no un-authorised access is permitted, and give directions to site office

Site signage must be erected prior to the commencement of works and be maintained for the duration of works.

5.1.5 Housekeeping / project site amenity

Site appearance and tidiness is an important measure in reducing environmental and safety risk during construction.

Rohrig will regularly inspect and maintain damage to environmental controls, project site fencing, the project site compound, and shared roads.

The project site will be managed to keep it generally tidy to enable more effective environmental management and maintain visual amenity.

5.1.6 Site vehicles

All construction vehicles will be contained wholly within the work site and defined parking areas. All construction related vehicles must enter and exit the site via the defined site access points and not impede traffic on surrounding streets.

There must be sufficient parking facilities on-site, including for heavy vehicles and for site personnel, to ensure that construction traffic associated with the development does not utilise public and residential streets or public parking facilities.

5.1.7 Driver code of conduct

Prior to the commencement of construction a Driver Code of Conduct is to be prepared and communicated to heavy vehicle drivers as part of induction. This must be adhered to in order to minimise impacts of construction on the local and regional road network by managing access routes and driver behaviour.

5.1.8 *Avoiding obstruction to the public*

Public access, pedestrian or vehicle paths must not be obstructed by any materials, vehicles, refuse, skips or the like, under any circumstances outside of any approved construction work zones.

6 Environmental framework

6.1 Environmental Policy



Environmental Policy

Rohrig is a proudly Australian company which, through hard work, inclusion and strong leadership, activates the potential in both our people and our projects. We work side-by-side with every client to ensure we maximise the value of the building for its life.

Rohrig is a commercial construction company based in New South Wales and Queensland, established by Glenn Rohrig in 1991. Since our inception we've created outstanding value across a range of sectors including education, hospitality, aged care, commercial, industrial and retail. We work collaboratively and transparently to bring your vision to life. With family values and a strong culture, we are determined to fulfil every promise. We stand behind your building for life.

Our construction and planning services include:

- Early Contractor Involvement (ECI)
- Design Management
- Detailed Design
- Practical Construction.

As a responsible business entity, we have an obligation to ensure our workers (including contractors and sub-consultants), clients and visitors at our premise, do not harm the environment as a result of our operations.

We at Rohrig acknowledge the importance of protecting the environmental as part of the community. In saying that we aspire to being a sustainable organisation which goes beyond minimising harm to the environment. To achieve this, we will endeavour to:

- ensure our management system complies with the requirements of ISO 14001:2015 - Environmental Management Systems
- implementing procedures and processes to identify, prevent and mitigate undesirable environmental impacts.
- identify the environmental risks to those potentially impacted by our operations and deploy the principles of the Hierarchy of Control to reduce such risk to the lowest levels possible
- comply with all relevant statutory obligations, regulations, and codes of practice.
- establish an environmentally friendly workplace designed to prevent pollution and or waste.
- promote and encourage environmental awareness and training to ensure individuals throughout our organisation are aware of their environmental responsibilities.
- executing and undertaking our operations in accordance with our management system
- fostering a collaborative approach between top management and workers to achieve a sustainable outcome.

It is important to note that environmental management is a shared accountability as well as an individual responsibility, for all persons impacted by our operations. At Rohrig, we seek the co-operation of all our stakeholders to achieve our environmental objectives. We emphasize the requirement to comply with the company's safe work practices at all times so that the environment is not harmed.

Rohrig will always encourage suggestions to improve our environmental objectives and work towards keeping environmental harm to a minimum in a sustainable, economically and feasible manner.

This policy applies to all business operations and functions and binds all its relevant stakeholders.

A handwritten signature in black ink, appearing to read "Glenn Rohrig".

Glenn Rohrig
Managing Director

1st May 2024

6.2 Environmental Management System

Rohrig maintain systems to meet the requirements of ISO14001:2015 Environmental management systems.

Figure 6-1 EMS certification



6.3 Project environmental expectations

Rohrig are committed to operating in a manner that conserves resources & protects the environment.

To achieve this goal, they make environmental management a priority on all their sites and require active participation by everyone to adequately plan the work they are carrying out and to always act responsibly by adhering to the following principles:

- If a task cannot be carried out with no or minimal impact on the environment, they STOP immediately and only proceed when risk mitigation is in place at an acceptable level
- They make sure we have the appropriate consent, or that the correct level of risk assessment is done to reduce the potential impact risks associated with our work
- They minimise their waste and recycle/reuse as and when appropriate
- They prevent pollution and manage resources efficiently in all their activities
- They comply with all applicable codes of practice, standards and legislation, relevant to the project
- They continually strive to improve their environmental performance
- They promote a culture of environmental awareness and commitment
- They proactively support environmentally aware design and engineering solutions

6.4 General Responsibilities

Rohrig recognises that a successful business in today's working environment must focus on ensuring that the environment is not compromised at any stage or level in its business operations.

To this end, Rohrig takes an uncompromising position to these critical issues on any project under their control. An approach of zero-tolerance is maintained, and potential removal of any persons working on Rohrig projects and under the control of Rohrig who creates a danger or risk of harming themselves, others or the environment from this project.

7 Project environmental management

The following sections detail the project specific requirement for environmental management during Stage 1 construction works.

7.1 Outdoor Lighting

Works will be undertaken during standard construction hours as specified in Section 3.2.4 of this CEMP. Construction lighting for night works will not be required for this project.

Prior to the installation of permanent outdoor lighting, Rohrig will submit evidence to the Certifier that all outdoor lighting within the site has been designed to comply with AS 1158.3.1:2005 Lighting for roads and public spaces – Pedestrian area (Category P) lighting – Performance and the design requirements and AS 4282-2019 Control of the obtrusive effects of outdoor lighting.

7.2 Plant and equipment

All construction plant and equipment used on site must be regularly checked and maintained to minimise risk of spills.

Plant and equipment are to be operated in a proper and efficient manner and turned off when not in use to minimise fuel use, noise and vehicle emissions.

7.3 Refuelling

Plant will be refuelled from truck tanker bowsers wherever possible. Refuelling must be undertaken in a defined and contained area away from down gradient site boundaries and stormwater drains.

Refuelling of small items of equipment from portable containers is permitted. Care is to be taken to minimise risk of spills using funnels and drip trays during refuelling.

Spill kits are to be stocked and readily available and deployed for immediate clean up if fuel spills occur.

Fuel hoses and pumps are not to be left unattended while in use.

Vehicles will be refuelled offsite.

7.4 Spill mitigation

Rohrig and all sub-contractors will undertake a regular inspection and maintenance program for vehicle, plant and equipment to identify potential leaks and correct them immediately.

Washing, degreasing, services, cleaning or other maintenance of vehicles, plant or other equipment must not occur in any area where resulting contaminants may be released to any stormwater drain, land or waters.

7.5 Chemical storage and handling

Chemical purchase choices are based on the product being as environmentally friendly as possible prior to bringing to site. A register of all chemicals and hazardous substances stored on-site will be maintained.

- All stored chemicals must have correct label and relevant SDS available on-site (hard copy or digital)

- Chemicals should be stored correctly in a secure bunded area and stored safely for the specific chemical as per the SDS.
- The net capacity of the storage bund should be maintained at least 110% of the largest container
- Emergency spill kits are to be maintained and readily available whenever oils, fuels or chemicals are stored or handled and where plant is operating.
- All personnel are to be familiar with the location and procedures for using the spill kit and trained if necessary
- Ensure spills and leaks are promptly and appropriately contained and cleaned-up and supervisor notified.
- Disposal of chemicals is to be as per the requirements in the SDS.
- Containers should be recyclable where possible, otherwise disposed of correctly as per the label.

7.6 Traffic management and project site access

All site vehicles are to enter and exit via the defined project access routes. Refer to Appendix B Traffic Management plan for further details.

7.7 Construction noise and vibration

A Construction Noise and Vibration Management Plan (CNVMP) is included as Appendix A to this CEMP and details mitigation measures and work practices to minimise minimal impacts during the construction phase.

7.8 Erosion and sediment control

Refer to **Error! Reference source not found.** Erosion and Sediment Control Plan for site specific detail.

Erosion and sediment controls are to be in place for the duration of ground disturbance.

All erosion and sediment controls are to be installed as per Soils and Construction Volume 1, 4th ed 2004 Managing Urban Stormwater (The Bluebook).

The following general principles are to be adhered to during works:

- Minimise disturbance footprint through appropriate works planning.
- Focus on erosion control as a priority where applicable.
- Install sediment controls before disturbing ground and for the duration of disturbance.
- Monitor and maintain controls to ensure function, especially before and after rain.
- Progressive stabilisation of disturbed areas should be undertaken during works.
- Modify/update the Erosion and Sediment Control Plan (ESCP) as required as site conditions change.

Weather conditions should be monitored and works planned in accordance to reduce likelihood or sedimentation on-site.

Excavated materials may be temporarily stockpiled for reuse on-site or removal depending on construction requirements. Stockpiles are to be minimised, have downslope sediment control in place, and covered if excess wet or windy weather is forecast.

Vehicle entry and exits must be via the designated area that is stabilised to prevent mud tracking.

Sediment transported on any road must be cleaned via brooming prior to the end of shift or the prior to rainfall.

Bare soil areas should be stabilised progressively with vegetation or other temporary or permanent measure throughout the works to reduce erosion.

Dirty water is not to be discharged into stormwater drains on the project site, all stormwater drains and inlets within the project site footprint and directly downslope are to have sediment control in place for duration of works to avoid sediment discharge from the project site.

Ensure all temporary erosion and sediment controls are removed at the completion of the works or when sufficient ground cover for permanent stabilisation is achieved.

7.9 Dust mitigation

During construction works must be undertaken so that activities are carried out in a manner that minimises dust including emission of wind-blown or traffic generated dust.

Demolition of existing buildings has been completed prior to Stage 1 construction works and all potentially hazardous in situ building materials removed from site.

Mitigation measures are to be implemented to reduce the risk of dust generation during Stage 1 works including:

- All trucks to have their loads covered
- Vehicle speed limits are to be reduced to low speeds (<20kmh) on unsealed road surfaces
- The main vehicular access to the site from Morris Grove will be bitumen sealed
- Unsealed access roads are to be monitored and maintained to reduce vehicle generated dust.
- A water sprinkler system will be utilised during construction to mitigate dust generation
- A stable site access (grid) is constructed so that vehicles do not track dirt onto the sealed road network
- Public roads adjacent to the site are monitored and cleaned of dirt if required using manual or plant mounted brooms (not hosed into stormwater)
- Disturbed areas are to be stabilised progressively on site to minimise exposed soil surfaces.
- Bare soil areas or stockpiles that generate dust are to be stabilised or covered
- Demolition works are to have dust mitigation measures in place such as hosing or misting to reduce dust

If dust cannot be kept within the site boundary, then works should be stopped and methodology reviewed to mitigate dust generation.

7.10 Heritage

No Aboriginal or European cultural heritage constraints have been identified for the proposed development.

Note that there is potential for isolated pockets of surviving A horizon soils in construction area.

Refer to section 8.2 Unexpected finds protocol for procedures on how to manage heritage finds during the works.

7.11 Vegetation protection

Vegetation is not to be disturbed outside the defined works footprint.

All construction plant and equipment are to be stored within the defined cleared site footprint and not within any tree protection areas.

All areas outside the defined works footprint are designated as No Go for plant and vehicles.

All works are to be consistent with **Section 3.0 of the Arboriculture Impact Assessment Report** – Stage 1 prepared by Arterra as per the EIS.

7.12 Waste management

All waste generated by the project, is to be beneficially reused or recycled as a priority over disposal to landfill.

Recyclable site and construction waste is to be recycled in accordance with the NSW Government’s “Waste Reduction and Purchasing Policy (WRAPP guidelines)”.

All waste generated during construction is to be contained within the defined compound waste storage area.

All waste generated during construction must be assessed, classified and managed in accordance with the Waste Classification Guidelines Part 1: Classifying Waste (EPA, 2014).

Concrete pump out waste is to be contained within a designated lined wash out bund. Waste concrete is to be allowed to go off then removed for recycling offsite. No concrete slurry is to be disposed of onto ground or stormwater.

During construction, the waste register is to be maintained and record the quantities of each waste type generated during construction and the proposed reuse, recycling and disposal locations for the duration of construction.

Any hazardous materials requiring disposal during construction will be disposed of at a licenced waste disposal facility and records retained.

7.12.1 Waste streams

WASTE TYPE	ESTIMATED VOLUME	DISPOSAL
Bricks	>10m ³	Recycle
Concrete	>10m ³	Recycle
Tiles	<10m ³	Recycle
Timber (clean)	<10m ³	Recycle
Timber (treated)	<10m ³	Recycle
Asphalt	>10m ³	Recycle
Metals	>10m ³	Recycle
Plasterboard	>10m ³	Recycle
Green waste	<10m ³	Recycle
Plastic/cardboard	<10m ³	Recycle
General other	<10m ³	Landfill
Wastewater	<10m ³	Sewer/pump out

TOTAL	900m ³
-------	-------------------

7.12.2 Disposal contractors

MET Recycling 134 Carnarvon Street, Silverwater, NSW 2128. EPA Licence [EPA Licence link here.](#)

BINGO Bins 1 Kangaroo Avenue, Eastern Creek NSW [EPA licence link here.](#)

7.13 Imported materials

All soil or quarry materials imported to site must be certified as either Virgin excavated natural material (VENM), Excavated natural material (ENM), or other that meets the requirements of a relevant order and exemption issued by the NSW EPA.

<https://www.epa.nsw.gov.au/your-environment/recycling-and-reuse/resource-recovery-framework/current-orders-and-exemption>

All soil materials imported to site are to have accurate records retained of the source, volume and type of fill. These records are to be retained and made available to the Certifier upon request.

7.14 Contamination

The existing building demolition has been completed prior to these Stage 1 construction works.

Geotechnical investigations undertaken at the site, including for potential site contamination, have identified that there is no obvious contamination of site soils within the construction area for the Bryson Building.

Refer to section 8.2.4 Unexpected finds – contamination for procedures for managing potential contamination identified during construction.

8 Contingency Plans

8.1 Environmental Incidents

An incident is defined as an occurrence or set of circumstances that causes or threatens to cause material harm to the environment. This may include:

- pollution to land or water from a spillage or leak of a substance such as fuel or oil.
- unauthorised damage to native flora and fauna.
- failure of erosion and sediment control devices leading to sediment pollution of waterways or stormwater.
- unexpected finds of hazardous materials or heritage.
- damage to known heritage items or protected flora or fauna species.
- any contractual or compliance breaches.

If an emergency incident occurs, Rohrig emergency management plans (Included as Appendix E) are to be followed, with safety a priority.

As part of an incident response, an investigation will be undertaken and mitigation measures will be reviewed, and the CEMP updated to reduce risk of future incident.

8.1.1 *Incident response and investigation*

The following incident procedure steps will be followed if an incident occurs:

- 1 Stop work in affected area if necessary. Notify Rohrig site supervisor/Project manager of incident.
- 2 Safety is the primary concern, and no action should be taken if it is not safe to do so. If it is unsafe to act, isolate the area and notify emergency services (000).
- 3 If the incident can be managed locally, action must be undertaken to contain and minimise the effect of the incident on the environment.
- 4 Once made safe, notify the Project Manager and log the incident in Procure.
- 5 Investigation of incident will be undertaken by the Project Manager or suitable representative and include as a minimum:
 - Location of incident.
 - Nature of incident.
 - Time of incident.
 - Time of reporting incident.
 - Immediate control action.
 - Rectification measures implemented

The incident investigation will determine causality and identify improvements to mitigation measures to be implemented to prevent future harm to the environment.

8.1.2 *Spill management and response*

If a spill of chemical occurs to ground:

- 1 Stop the spill at source as priority provided it is safe to do so
- 2 Report the spill incident immediately to Rohrig Site supervisor/Project manager
- 3 Identify chemical and if there are any WHS risks associated. Refer to SDS for information
- 4 Contact the NSW Fire and Rescue on 000 if the spill presents a risk of harm to people or the environment
- 5 If spill is manageable, contain and clean up using spill kit to contain and absorb the spilled material (Chemical spills should never be hosed away by water)
- 6 If soil has become contaminated, remove and dispose of as contaminated material
- 7 Ensure that any used spill kit materials (contaminated waste) are disposed appropriately
- 8 Investigate the cause of each spill to find and implement preventative actions to reduce the risk of a similar incident occurring

8.1.3 *Incident notification to NSW Planning Secretary*

The Planning Secretary must be notified through the **major projects portal** immediately after Rohrig becomes aware of an incident.

The notification must identify the development (including the development application number and the name of the development if it has one) and set out the location and nature of the incident.

8.1.3.1 *Written Incident Notification Requirements*

A written incident notification addressing the requirements set out below must be emailed to the Planning Secretary through the major projects portal within 7 (seven) days after becoming aware of an incident.

Notification is required to be given even if the immediate notification has not been given or if, having given such notification already, it becomes clear that an incident has not actually occurred.

Written notification of an incident must include the following information:

- Identify the development approval number
- Provide details of the incident including date, time, location, a brief description of what occurred and why it is classified as an incident
- Identify how the incident was detected
- Identify when Rohrig became aware of the incident
- Identify any actual or potential non-compliance with conditions of consent
- Describe what immediate steps were taken in relation to the incident
- Identify further action(s) that will be taken in relation to the incident
- Provide a project contact for further communication regarding the incident.

Within 30 (thirty) days of the date on which the incident occurred or as otherwise agreed to by the Planning Secretary, Rohrig must provide the Planning Secretary and any relevant public authorities (as determined by the Planning Secretary) with a detailed Incident Report on the incident addressing all requirements below, and such further reports as may be requested.

The Incident Report must include:

- A summary of the incident
- Outcomes of an incident investigation, including identification of the cause of the incident
- Details of the corrective and preventative actions that have been and/or will be implemented to address the incident and prevent recurrence
- Details of any communication with other stakeholders regarding the incident.

8.1.4 *EPA Reporting*

Where an incident would equate to a reportable incident under the NSW POEO Act 1997, the NSW EPA is to also be notified within 24 hours of the incident occurring.

A reportable incident is defined as one that may cause material harm to the environment or a pollution incident.

- Material harm includes on-site harm, as well as harm to the environment beyond the premises where the pollution incident occurred.
- Pollution incident means an incident or set of circumstances during or as a consequence of which there is or is likely to be a leak, spill or other escape or deposit of a substance, as a result of which pollution has occurred, is occurring or is likely to occur.

<https://www.epa.nsw.gov.au/reporting-and-incidents/incident-management/duty-to-notify-pollution-incidents>

8.2 Unexpected Finds Protocols

8.2.1 *Unexpected finds – Aboriginal heritage*

In the event that excavation disturbs or identifies an Aboriginal object or suspected A horizon soils:

- All works must halt in the immediate area to prevent any further impacts to the suspected object(s)
- The area is to be demarcated and protected from further harm
- A suitably qualified archaeologist be engaged to identify and confirm object and the registered Aboriginal representatives must be contacted to determine the significance of the objects once verified
- If items are verified, the site is to be registered in the Aboriginal Heritage Information Management System (AHIMS) which is managed by Heritage NSW and consultation is to occur with the relevant Aboriginal community representatives, the archaeologists and Heritage NSW to develop and implement management strategies for the objects and site.

Works may only then recommence with the written approval of the Planning Secretary.

8.2.2 *Unexpected finds – skeletal remains*

In the event that a burial or skeletal remains are uncovered during work, then:

- All works must halt in the immediate area to prevent any further impacts to the suspected object(s)
- The area is to be demarcated and protected from further harm
- NSW Police and Heritage NSW are to be notified to guide next actions depending on the nature of the find

- A suitably qualified archaeologist may be required to determine the specific nature and significance of the skeletal remains and consultation with relevant stakeholders, the archaeologists and Heritage NSW would then be required to implement appropriate management strategies for the skeletal remains.
- Works may only then recommence with the written approval of Heritage NSW.

8.2.3 *Unexpected Finds Protocol – Historic Heritage*

If any unexpected suspected archaeological relics are uncovered during the work, then:

- All works must halt in the immediate area to prevent any further impacts to the suspected object(s)
- The area is to be demarcated and protected from further harm
- A suitably qualified archaeologist be engaged to identify and confirm object
- If confirmed, notice is to be given to Heritage NSW and the Planning Secretary
- Depending on the possible significance of the object, an archaeological assessment and management strategy may be required before further works can continue in that area as determined in consultation with Heritage NSW

Works may only then recommence with the written approval of the Planning Secretary.

8.2.4 *Unexpected finds - contamination*

If any suspected contamination or hazardous substance is identified during works, then:

- All works must halt in the immediate area to prevent any exposure or risk to safety or the environment
- The area is to be demarcated and protected from further disturbance
- A suitably qualified contaminated lands specialist be engaged to test, identify and produce a plan to mitigate the risk of harm from contamination.

8.2.4.1 *Asbestos handling*

If unexpected asbestos is identified during construction in structures or in soil, Rohrig must consult with a suitable qualified specialist and SafeWork NSW concerning the handling of any asbestos waste that may be generated.

The requirements of the Protection of the Environment Operations (Waste) Regulation 2014 with particular reference to Part 7 – ‘Transportation and management of asbestos waste’ must also be complied with.

Works may only then recommence once risk of harm is mitigated.

8.2.5 *Wet weather*

The project site will be made safe and stable and shut down where required in excessive wet weather.

Earthworks will be avoided in wet conditions.

Erosion and sediment controls will be in place and functional prior to any shutdown.

8.2.6 *Flood management*

Flood risk from riverine flooding is not likely to occur at this site. Stage 1 works are located in the higher, southern portion of the subject site, where ground levels are more than 1 m higher than the 1% AEP flood levels.

Local stormwater systems may experience localised issues during high intensity rainfall events and extreme weather conditions such as flood forecast is to be monitored and factored into works planning day to day.

8.3 CEMP Review and update

The CEMP is to be considered a live document and should be reviewed and updated during the project if the scope or any other environmental aspect changes.

A copy of the current CEMP is to be available on-site during the construction works.

Any revisions required are to be incorporated into an updated version and document made current.

Changes to this plan will be approved by the contractor's Project Manager documented in the document control section for each revision.

A copy of the updated plan and changes will be distributed to all relevant stakeholders.

8.4 Audit

As per the development consent section D35 Independent Audits of the works must be conducted and carried out in accordance with the *Independent Audit Post Approval Requirements (2020)*.

<https://www.planning.nsw.gov.au/sites/default/files/2023-02/independent-audit-par-202005.pdf>

9 Limitations

This Report is provided by WSP Australia Pty Limited (WSP) for Rohrig (Client) in response to specific instructions from the Client and in accordance with WSP's proposal dated 7/12/2022 and agreement with the Client dated 7/3/2023 (Greencap [owned by WSP] Terms and Conditions).

9.1 Permitted purpose

This Report is provided by WSP for the purpose described in the Agreement and no responsibility is accepted by WSP for the use of the Report in whole or in part, for any other purpose (Permitted Purpose).

9.2 Qualifications and assumptions

The services undertaken by WSP in preparing this Report were limited to those specifically detailed in the Report and are subject to the scope, qualifications, assumptions and limitations set out in the Report or otherwise communicated to the Client.

Except as otherwise stated in the Report and to the extent that statements, opinions, facts, conclusion and / or recommendations in the Report (Conclusions) are based in whole or in part on information provided by the Client and other parties identified in the report (Information), those Conclusions are based on assumptions by WSP of the reliability, adequacy, accuracy and completeness of the Information and have not been verified. WSP accepts no responsibility for the Information.

WSP has prepared the Report without regard to any special interest of any person other than the Client when undertaking the services described in the Agreement or in preparing the Report.

9.3 Use and reliance

This Report should be read in its entirety and must not be copied, distributed or referred to in part only. The Report must not be reproduced without the written approval of WSP. WSP will not be responsible for interpretations or conclusions drawn by the reader. This Report (or sections of the Report) should not be used as part of a specification for a project or for incorporation into any other document without the prior agreement of WSP.

WSP is not (and will not be) obliged to provide an update of this Report to include any event, circumstance, revised Information or any matter coming to WSP's attention after the date of this Report. Data reported and Conclusions drawn are based solely on information made available to WSP at the time of preparing the Report. The passage of time; unexpected variations in ground conditions; manifestations of latent conditions; or the impact of future events (including (without limitation) changes in policy, legislation, guidelines, scientific knowledge; and changes in interpretation of policy by statutory authorities); may require further investigation or subsequent re-evaluation of the Conclusions.

This Report can only be relied upon for the Permitted Purpose and may not be relied upon for any other purpose. The Report does not purport to recommend or induce a decision to make (or not make) any purchase, disposal, investment, divestment, financial commitment or otherwise. It is the responsibility of the Client to accept (if the Client so chooses) any Conclusions contained within the Report and implement them in an appropriate, suitable and timely manner.

In the absence of express written consent of WSP, no responsibility is accepted by WSP for the use of the Report in whole or in part by any party other than the Client for any purpose whatsoever. Without the express written consent of WSP, any use which a third party makes of this Report or any reliance on (or decisions to be made) based on this Report

is at the sole risk of those third parties without recourse to WSP. Third parties should make their own enquiries and obtain independent advice in relation to any matter dealt with or Conclusions expressed in the Report.

9.4 Disclaimer

No warranty, undertaking or guarantee whether expressed or implied, is made with respect to the data reported or the Conclusions drawn. To the fullest extent permitted at law, WSP, its related bodies corporate and its officers, employees and agents assumes no responsibility and will not be liable to any third party for, or in relation to any losses, damages or expenses (including any indirect, consequential or punitive losses or damages or any amounts for loss of profit, loss of revenue, loss of opportunity to earn profit, loss of production, loss of contract, increased operational costs, loss of business opportunity, site deprecation costs, business interruption or economic loss) of any kind whatsoever, suffered on incurred by a third party.

Appendix A

Noise and Vibration Management Plan



Appendix B

Traffic Management Plan



Appendix C

Erosion and Sediment Control plan



Appendix D

Community Engagement Strategy



Appendix E

Emergency Management Plan



Appendix F

Site layout



Appendix G

EMP Checklists



G1 EMP Checklist

The below Table 9-2 Conditions of consent - CEMP reference section shows where the specific conditions of consent (as per EIS) have been addressed in this CEMP document.

Table 9-1 CEMP checklist is as per Environmental Management Plan Guideline for Infrastructure Projects (April 2020 NSW Department of Infrastructure Assessments, Planning and Assessment).

Table 9-2 Conditions of consent - CEMP reference section shows where the specific conditions of consent (as per EIS) have been addressed in this CEMP document.

Table 9-1 CEMP checklist

Requirement	Y / N / NA
Has the EMP been prepared in consultation with all relevant stakeholders as per the requirements of the conditions of consent?	
Have the views of the relevant stakeholders been taken into consideration? Have appropriate amendments been made to the EMP and does the EMP clearly identify the location of any changes?	
Has the EMP been internally approved by an authorised representative of the proponent or contractor?	
Does the EMP describe the proponent's Environmental Management System (EMS) (if any), and identify how the EMP relates to other documents required by the conditions of consent?	Y
Does the EMP include the required general content and version control information?	Y
Does the EMP have an introduction that describes the project, scope of works, site location and any staging or timing considerations?	Y
Does the EMP reference the project description? (Section 3.3)	Y
Does the EMP reference a Community and Stakeholder Engagement Plan (or similar) or include community and stakeholder engagement actions (if required)?	Y
Have all other relevant approvals been identified? Has appropriate information been provided regarding how each approval is relevant?	Y
Has the environmental management structure and responsibilities been included?	Y
Does the EMP include processes for training of project personnel and identify how training and awareness needs will be identified?	Y
Does the EMP clearly identify the relevant legal and compliance requirements that relate to the EMP?	Y

Does the EMP include all the conditions of consent to be addressed by the EMP and identify where in the EMP each requirement has been addressed?	Y
Have all relevant guidelines, policies and standards been identified, including details of how they are relevant?	Y
Is the process that will be adopted to identify and analyse the environmental risks included?	NA (EIS)
Have all the environmental management measures in the EIA been directly reproduced into the EMP?	Y
Have any additional environmental management measures been included in the EMP?	Y
Have environmental management measures been written in committed language?	Y
Have project environmental management measures, including hold points, been identified and included?	Y
Are relevant details of environmental monitoring that will be carried out included?	Y
Have the components of any environmental monitoring programs been incorporated?	Y
Are environmental inspections included? Does the EMP document all relevant compliance monitoring and reporting requirements for the project?	Y
Does the EMP describe the types of plans or maps (such as environmental control maps) that will be used to assist with the management of environmental matters on site?	Y
Does the EMP list environmental management documents?	NA
Is an auditing program referenced?	Y
Does the EMP include the incident notification and reporting protocols that comply with the relevant conditions of consent?	Y
Does the EMP identify the project role/position that is responsible for deciding whether an occurrence is an incident?	Y
Does the EMP describe a corrective and preventative action process that addresses the requirements?	Y
Does the EMP include details of a review and revision process that complies with the requirements?	Y

Table 9-2 Conditions of consent - CEMP reference section

Condition	Requirement	CEMP reference
C1	The Applicant must notify the Planning Secretary in writing of the dates of the intended commencement of construction and operation at least 48 hours before those dates	4.1
C2	If the construction or operation of the development is to be staged, the Planning Secretary must be notified in writing at least 48 hours before the commencement of each stage, of the date of commencement and the development to be carried out in that stage.	4.1
C5	Pre-Construction Survey – Adjoining Properties Prior to the commencement of any construction, the Applicant must offer a pre-construction survey to owners of residential/commercial buildings that are likely to be impacted by the development.	Appendix A
C6	Where the offer for a pre-construction survey is accepted (as required by Schedule 3 condition C5), the Applicant must arrange for a survey to be undertaken by a suitably qualified and experienced expert prior to the commencement of vibration generating works that could impact on the identified buildings.	
C7	Prior to the commencement of any vibration generating works that could impact on the buildings surveyed as required by Schedule 3 condition C5, the Applicant must: <ul style="list-style-type: none"> (a) provide a copy of the relevant survey to the owner of each residential building surveyed in the form of a Pre-Construction Survey Report; (b) submit a copy of the Pre-Construction Survey Report to the Certifier (c) provide a copy of the Pre-Construction Survey Report to the Planning Secretary when requested. 	
C8	Community Communication Strategy No later than two weeks before the commencement of any construction, a Community Communication Strategy must be submitted to the Planning Secretary for information. The Community Communication Strategy must provide mechanisms to facilitate communication between the Applicant, the relevant Council and the community (including adjoining affected landowners and businesses, and others directly impacted by the development), during the design and construction of the development and for a minimum of 12 months following the completion of construction.	Appendix D
C9	The Community Communication Strategy must: <ul style="list-style-type: none"> (a) identify people to be consulted during the design and construction phases (b) set out procedures and mechanisms for the regular distribution of accessible information about or relevant to the development; (c) provide for the formation of community-based forums, if required, that focus on key environmental management issues for the development; (d) set out procedures and mechanisms: <ul style="list-style-type: none"> (i) through which the community can discuss or provide feedback to the Applicant; 	

	<p>(ii) through which the Applicant will respond to enquiries or feedback from the community; and</p> <p>(iii) to resolve any issues and mediate any disputes that may arise in relation to construction and operation of the development, including disputes regarding rectification or compensation.</p> <p>(e) include any specific requirements around traffic, noise and vibration, visual impacts, amenity, flora and fauna, soil and water, contamination, heritage.</p>	
C12	<p>Outdoor Lighting</p> <p>Prior to the installation of outdoor lighting, evidence must be submitted to the Certifier that all outdoor lighting within the site has been designed to comply with AS 1158.3.1:2005 Lighting for roads and public spaces – Pedestrian area (Category P) lighting – Performance and design requirements and AS 4282-2019 Control of the obtrusive effects of outdoor lighting.</p>	7.1
C13 C14	<p>Management plans required under this consent must be prepared having regard to relevant guidelines, including but not limited to the Environmental Management Plan Guideline: Guideline for Infrastructure Projects (DPIE April 2020).</p> <p>Construction Environmental Management Plan</p>	<p>Error! Reference source not found.</p> <p>This CEMP</p>
C15	<p>The Applicant must not commence construction of the development until the CEMP is approved by the Certifier and a copy submitted to the Planning Secretary.</p>	1.5
C16	<p>The Construction Traffic and Pedestrian Management Sub-Plan (CTPMSP) must be prepared to achieve the objective of ensuring safety and efficiency of the road network and address, but not be limited to, the following:</p> <p>(a) be prepared by a suitably qualified and experienced person(s);</p> <p>(b) be consistent with the Section 9 - Construction Pedestrian and Traffic Management Plan Methodology (Stage 1) in the Traffic Impact Assessment prepared by Ptc dated 27 June 2023;</p> <p>(c) be prepared in consultation with Council and TfNSW;</p> <p>(d) detail the measures that are to be implemented to ensure road safety and network efficiency during construction in consideration of potential impacts on general traffic, cyclists and pedestrians and bus services; and</p> <p>(e) detail heavy vehicle routes, access and parking arrangements.</p>	Appendix B
C17	<p>The Construction Noise and Vibration Management Sub-Plan (CNVMSP) must address, but not be limited to, the following:</p> <p>(a) be prepared by a suitably qualified and experienced noise expert;</p> <p>(b) be consistent with recommendations in Stage 1 Works Noise and Vibration Impact Assessments dated 20 March 2023 and prepared by SLR Consulting Australia Pty Ltd;</p> <p>(c) describe procedures for achieving the noise management levels in EPA's Interim Construction Noise Guideline (DECC, 2009);</p>	Appendix A

	<p>(d) describe the measures to be implemented to manage high noise generating works such as piling, in close proximity to sensitive receivers;</p> <p>(e) include strategies that have been developed with the community for managing high noise generating works;</p> <p>(f) describe the community consultation undertaken to develop the strategies in Schedule 3 condition C17(e);</p> <p>(g) include a complaints management system that would be implemented for the duration of the construction; and</p> <p>(h) include a program to monitor and report on the impacts and environmental performance of the development and the effectiveness of the management measures in accordance with Schedule 3 condition C13.</p>	
C18	<p>The Applicant must prepare a Construction Soil and Water Management Plan (CSWMSP) and the plan must address, but not be limited to the following:</p> <p>(a) be prepared by a suitably qualified expert, in consultation with Council</p> <p>(b) describe all erosion and sediment controls to be implemented during construction, as a minimum, in accordance with the publication Managing Urban Stormwater: Soils & Construction (4th edition, Landcom 2004) commonly referred to as the 'Blue Book'</p> <p>(c) provide a plan of how all construction works will be managed in a wet-weather events (i.e. storage of equipment, stabilisation of the site);</p> <p>(d) detail all off-site flows from the site; and</p> <p>(e) describe the measures that must be implemented to manage stormwater and flood flows for small and large sized events, including, but not limited to, 1 in 5-year ARI and 1 in 100-year ARI).</p>	<p>Error! Reference source not found.</p> <p>7.8</p> <p>8.2.6</p>
C19	<p>Prior to the commencement of any construction a Driver Code of Conduct must be prepared and communicated by the Applicant to heavy vehicle drivers and must address the following: (a) minimise the impacts of earthworks and construction on the local and regional road network; (b) minimise conflicts with other road users; (c) minimise road traffic noise; and (d) ensure truck drivers use specified route</p>	5.1.7
C20	<p>Unexpected Contamination Procedure</p> <p>Prior to the commencement of any construction, the Applicant must prepare an unexpected contamination procedure to ensure that potentially contaminated material is appropriately managed. Where any material identified as contaminated is to be disposed off-site, the disposal location and results of testing submitted to the Planning Secretary prior to its removal from the site.</p>	8.2.4
C21	<p>Construction Parking</p> <p>Prior to the commencement of any construction, the Applicant must provide sufficient parking facilities on-site, including for heavy vehicles and for site personnel, to ensure that construction traffic associated with the development does not utilise public and residential streets or public parking facilities.</p>	<p>3.2.6</p> <p>Site induction</p>
C22/23	<p>Site Contamination</p>	7.14

	Prior to the commencement of any construction, the Applicant must engage a NSW EPA-accredited Site Auditor to provide advice throughout the duration of works to ensure that any work required in relation to soil or groundwater contamination is appropriately managed.	
C24	Prior to the commencement of any construction, the Applicant must prepare and implement for the duration of construction: (a) flood warning and notification procedures for construction workers on site; and (b) evacuation and refuge protocols.	8.2.6
D1	Site Notice A site notice(s) must be prominently displayed at the boundaries of the site during construction for the purposes of informing the public of project details and must satisfy the following requirements: (a) minimum dimensions of the site notice(s) must measure 841 mm x 594 mm (A1) with any text on the site notice(s) to be a minimum of 30-point type size. (b) the site notice(s) must be durable and weatherproof and must be displayed throughout the works period. (c) the approved hours of work, the name of the builder, Certifier, structural engineer, site/ project manager, the responsible managing company (if any), its address and 24-hour contact phone number for any inquiries, including construction/ noise complaint must be displayed on the site notice; and (d) the site notice(s) must be mounted at eye level on the perimeter hoardings/fencing and must state that unauthorised entry to the site is not permitted.	5.1.4
D2	Operation of Plant and Equipment All construction plant and equipment used on site must be maintained in a proper and efficient condition and operated in a proper and efficient manner	7.2
D3	Demolition work must comply with the demolition work plans required by Australian Standard AS 2601-2001 The demolition of structures (Standards Australia, 2001) and endorsed by a suitably qualified person as required.	7.14
D4	Upon completion of the demolition works of the car park (including removal of the surface), the Applicant must submit to the Certifier, for information. (a) an asbestos clearance inspection and certificate, prepared and signed by a suitability qualified professional (SafeWork NSW Licensed Asbestos Assessor) (if asbestos is found); and (b) a statement confirming that a suitably qualified consultant has conducted inspection of the exposed surfaces.	7.14
D5	Construction, including the delivery of materials to and from the site, may only be carried out between the following hours: (a) between 7am and 6pm, Mondays to Fridays inclusive; and	3.2.4

	(b) between 8am and 1pm, Saturdays. No work may be carried out on Sundays or public holidays.	
D6	Construction activities may be undertaken outside of the hours in Schedule 3 condition D5 if required: (a) by the Police or a public authority for the delivery of vehicles, plant or materials; or (b) in an emergency to avoid the loss of life, damage to property or to prevent environmental harm; or (c) where the works are inaudible at the nearest sensitive receivers; or (d) where a variation is approved in advance in writing by the Planning Secretary or his nominee if appropriate justification is provided for the works.	3.2.4.1
D7	Notification of such construction activities as referenced in Schedule 3 condition D6 must be given to affected residents before undertaking the activities or as soon as is practical afterwards.	4.2
D8	Rock breaking, rock hammering, sheet piling, pile driving, and similar activities may only be carried out between the following hours: (a) 9am to 12pm, Monday to Friday. (b) 2pm to 5pm Monday to Friday; and (c) 9am to 12pm, Saturday.	3.2.8
D9	The Applicant must carry out the construction of the development in accordance with the most recent version of the approved CEMP (including Sub-Plans).	8.3
D10	All construction vehicles are to be contained wholly within the site, except if located in an approved on-street work zone, and vehicles must enter the site or an approved on-street work zone before stopping.	5.1.6
D11	The following hoarding requirements must be complied with: (a) no third-party advertising is permitted to be displayed on the subject hoarding/ fencing; and (b) the construction site manager must be responsible for the removal of all graffiti from any construction hoardings or the like within the construction area within 48 hours of its application.	5.1.2
D12	The public way (outside of any approved construction works zone) must not be obstructed by any materials, vehicles, refuse, skips or the like, under any circumstances.	5.1.8
D13	The development must be constructed to achieve the construction noise management levels detailed in the Interim Construction Noise Guideline (DECC, 2009). All feasible and reasonable noise mitigation measures must be implemented and any activities that could exceed the construction noise management levels must be identified and managed in accordance with the management and mitigation measures identified in the approved CNVMSP required by Schedule 3 condition C17.	Appendix A

D14	The Applicant must ensure construction vehicles (including concrete agitator trucks) do not arrive at the site or surrounding residential precincts outside of the construction hours of work outlined under Schedule 3 condition D5 unless approved by Schedule 3 condition D6.	
D15	The Applicant must implement, where practicable and without compromising the safety of construction staff or members of the public, the use of ‘quackers’ to ensure noise impacts on surrounding noise sensitive receivers are minimised.	
D16	Vibration caused by construction at any residence or structure outside the site must be limited to: (a) for structural damage, the latest version of DIN 4150-3 (1992-02) Structural vibration - Effects of vibration on structures (German Institute for Standardisation, 1999); and (b) for human exposure, the acceptable vibration values set out in the Environmental Noise Management Assessing Vibration: a technical guideline (DEC, 2006) (as may be updated or replaced from time to time).	Appendix A
D17	Vibratory compactors must not be used closer than 30m from residential buildings unless vibration monitoring confirms compliance with the vibration criteria specified in Schedule 3 condition D16.	
D18	The limits in Schedule 3 condition D16 and Schedule 3 condition D17 apply unless otherwise outlined in a CNVMSP required by Schedule 3 condition C17.	
D19	For the duration of the construction works: (a) street trees must not be trimmed or removed unless it forms a part of this development consent or prior written approval from Council is obtained or is required in an emergency to avoid the loss of life or damage to property; (b) all street trees immediately adjacent to the approved disturbance area / property boundaries must be protected at all times during construction in accordance with Council’s tree protection requirements. Any street tree, which is damaged or removed during construction due to an emergency, must be replaced, to the satisfaction of council; (c) all trees on the site that are not approved for removal must be suitably protected during construction as per the recommendations of the Arboricultural Impact Assessment Report – Stage 1 prepared by Arterra dated 15 July 2022; and (d) if access to the area within any protective barrier is required during the works, it must be carried out under the supervision of a qualified arborist. Alternative tree protection measures must be installed, as required. The removal of tree protection measures, following completion of the works, must be carried out under the supervision of a qualified arborist and must avoid both direct mechanical injury to the structure of the tree and soil compaction within the canopy or the limit of the former protective fencing, whichever is the greater.	7.11
D20	The Applicant must take all reasonable steps to minimise dust generated during all works authorised by this consent.	7.9
D21	During construction, the Applicant must ensure that: (a) activities are carried out in a manner that minimises dust including emission of windblown or traffic generated dust;	

	<p>(b) all trucks entering or leaving the site with loads have their loads covered;</p> <p>(c) trucks associated with the development do not track dirt onto the public road network;</p> <p>(d) public roads used by these trucks are kept clean; and</p> <p>(e) land stabilisation works are carried out progressively on site to minimise exposed surfaces.</p>	
D22	All erosion and sediment control measures must be effectively implemented and maintained in accordance with the CSWMSP required by Schedule 3 condition C18.	7.8
D23	<p>The Applicant must:</p> <p>(a) all soil materials designed for off-site disposal as part of the development, including any virgin excavated natural material, are pre-classified in accordance with EPA Waste Classification Guidelines (2014);</p> <p>(b) ensure that only VENM, ENM, or other material that meets the requirements of a relevant order and exemption issued by the EPA, is brought onto the site;</p> <p>(c) keep accurate records of the volume and type of fill to be used; and</p> <p>(d) make these records available to the Certifier upon request.</p>	7.12
D24	Adequate provisions must be made to collect and discharge stormwater drainage during construction of the building to the satisfaction of the Certifier. The prior written approval of Council must be obtained to connect or discharge site stormwater to Council's stormwater drainage system or street gutter.	
D25	The Applicant must prepare and implement awareness training for employees and contractors, including locations of the assembly points and evacuation routes, for the duration of construction	4.3
D26	<p>In the event that surface disturbance identifies a new Aboriginal object:</p> <p>(a) all works must halt in the immediate area to prevent any further impacts to the object(s);</p> <p>(b) a suitably qualified archaeologist and the registered Aboriginal representatives must be contacted to determine the significance of the objects;</p> <p>(c) the site is to be registered in the Aboriginal Heritage Information Management System (AHIMS) which is managed by Heritage NSW under Department of Premier and Cabinet and the management outcome for the site included in the information provided to AHIMS;</p> <p>(d) the Applicant must consult with the Aboriginal community representatives, the archaeologists and Heritage NSW to develop and implement management strategies for all objects/sites; and</p> <p>(e) works may only recommence with the written approval of the Planning Secretary.</p>	8.2.1
D27	<p>If any unexpected archaeological relics are uncovered during the work, then:</p> <p>(a) all works must cease immediately in that area and notice is to be given to Heritage NSW and the Planning Secretary;</p>	8.2.3

	<p>(b) depending on the possible significance of the relics, an archaeological assessment and management strategy may be required before further works can continue in that area as determined in consultation with Heritage NSW; and</p> <p>(c) works may only recommence with the written approval of the Planning Secretary.</p>	
D28	<p>In the event that a burial or skeletal remains are uncovered during work, then:</p> <p>(a) all works must cease immediately in that area and the NSW Police and Heritage NSW contacted;</p> <p>(b) a suitably qualified archaeologist must be contacted to determine the specific nature and significance of the skeletal remains;</p> <p>(c) the Applicant must consult with relevant stakeholders, the archaeologists and Heritage NSW to develop and implement appropriate management strategies for the skeletal remains; and</p> <p>(d) works may only recommence with the written approval of Heritage NSW.</p>	8.2.2
D29	<p>All waste generated during construction must be secured and maintained within designated waste storage areas at all times and must not leave the site onto neighbouring public or private properties.</p>	7.12
D30	<p>D30. All waste generated during construction must be assess, classified and managed in accordance with the Waste Classification Guidelines Part 1: Classifying Waste (EPA, 2014).</p>	
D31	<p>D31. The Applicant must ensure that concrete waste and rinse water are not disposed of on the site and are prevented from entering any natural or artificial watercourse.</p>	
D32	<p>D32. The Applicant must record the quantities of each waste type generated during construction and the proposed reuse, recycling and disposal locations for the duration of construction.</p>	
D33	<p>D33. The Applicant must ensure that the removal of hazardous materials, particularly the method of containment and control of emission of fibres to the air, and disposal at an approved waste disposal facility is in accordance</p>	
D34	<p>The Applicant must ensure that all external lighting is constructed and maintained in accordance with AS 4282-2019 Control of the obtrusive effects of outdoor lighting.</p>	7.1
D35-D40	<p>Independent Audits of the development must be conducted and carried out in accordance with the Independent Audit Post Approval Requirements (2020).</p>	8.4



ROHRIG CONSTRUCTION

AUG 2024

CONSTRUCTION NOISE AND VIBRATION MANAGEMENT PLAN

WILLIAM CLARKE
COLLEGE
KELLYVILLE, NSW

wsp



Question today Imagine tomorrow Create for the future

Construction Noise and Vibration Management Plan for William Clarke College Kellyville, NSW

Rohrig Construction

WSP

Level 3, 51-55 Bolton St

Newcastle NSW 2300

PO Box 1162



Newcastle NSW 2300

Tel: +61 2 4929 8300

Fax: +61 2 4929 8382

wsp.com

REV	DATE	DETAILS
0	29/08/2024	Draft Issue for client review

	NAME	DATE	SIGNATURE
Prepared by:	Mathieu Boué	29/08/2024	
Reviewed by:	Ben Ison	29/08/2024	
Approved by:	S Longman	30/8/24	

This document may contain confidential and legally privileged information, neither of which are intended to be waived, and must be used only for its intended purpose. Any unauthorised copying, dissemination or use in any form or by any means other than by the addressee, is strictly prohibited. If you have received this document in error or by any means other than as authorised addressee, please notify us immediately and we will arrange for its return to us.



TABLE OF CONTENTS

1	INTRODUCTION	1
1.1	PROJECT BACKGROUND	1
1.2	PROJECT LOCATION.....	1
1.3	PURPOSE OF THIS PLAN	2
1.4	RELEVANT GUIDELINES	3
2	EXISTING NOISE ENVIRONMENT	4
2.1	SITE LOCATION AND IDENTIFIED SENSITIVE RECEIVERS	4
2.2	BACKGROUND NOISE LEVELS	5
2.2.1	UNATTENDED NOISE SURVEYS	5
2.2.2	ATTENDED NOISE SURVEYS	6
3	CONSTRUCTION NOISE AND VIBRATION ASSESSMENT CRITERIA	7
3.1.1	DEVELOPMENT CONSENT CONDITIONS (APPLICATION NUMBER SSD 35715221).....	7
3.2	CONSTRUCTION NOISE	8
3.3	VIBRATION	11
3.3.1	COSMETIC BUILDING DAMAGE AND STRUCTURAL INTEGRITY	11
3.3.2	HUMAN COMFORT (AMENITY)	12
3.4	CONSTRUCTION TRAFFIC	12
4	ASSESSMENT OF NOISE AND VIBRATION IMPACTS	13
4.1	CONSTRUCTION ACTIVITIES.....	13
4.2	ASSESSMENT METHOD	14
4.3	PREDICTED NOISE LEVELS.....	15
4.4	DISCUSSION	16
4.5	VIBRATION ASSESSMENT	16
4.6	TRAFFIC ASSESSMENT	17
5	NOISE AND VIBRATION MANAGEMENT MEASURES	19
5.1	INTRODUCTION	19
5.2	NOISE MANAGEMENT	19



5.3	MANAGEMENT MEASURES	19
6	COMPLIANCE MANAGEMENT	22
6.1	TRAINING	22
6.2	MONITORING	22
6.3	COMPLAINTS MANAGEMENT	23
6.4	INSPECTIONS AND AUDITING	23
6.5	NON-COMPLIANCES	23
6.6	REPORTING	24
6.7	PLAN REVIEW	24

1 INTRODUCTION

The proposed construction works involves the construction of stage 1 works at William Clarke College in Kellyville NSW. This stage of work is part of an approved masterplan for the school to meet the demands of the growing local community.

Stage 1 works have been approved by the Minister for Planning and Public Spaces (NSW) under section 4.38 of the Environmental Planning and Assessment Act (1979).

The purpose of the Construction Environmental Management Plan (CEMP) is to meet the criteria as defined within the approved State Significant Development (SSD-35715221). Schedule 3 Part C of the conditions of consent, clause C14 states the requirement for preparation of a Construction Environmental Management Plan (CEMP). Under clause c) of this requirement, a Construction Noise and Vibration sub plan (CNVMP) must be produced.

WSP has been engaged to prepare this CNVMP to assist in the management of risks associated with construction of this project.

1.1 PROJECT BACKGROUND

The planned construction activities for achieving the scope of works are as follows:

- Site preparation, being tree removal; bulk earthworks; and civil works for the Bryson Building
- Construction of the Bryson Building for use as classrooms, staff rooms, library and ancillary teaching spaces, to be located in the centre of the site
- Landscaping ancillary to Bryson Building including tree planting

1.2 PROJECT LOCATION

The project site is within a school: William Clarke College, located at 10 Morris Grove, Kellyville NSW and is legally described as Lot 10 in DP 1169003).

The works footprint is Stage 1 works and is within the school grounds as shown in Figure 1.1.

Figure 1.1 William Clarke College Masterplan (Extract from EIS) – Stage 1 outlined in red

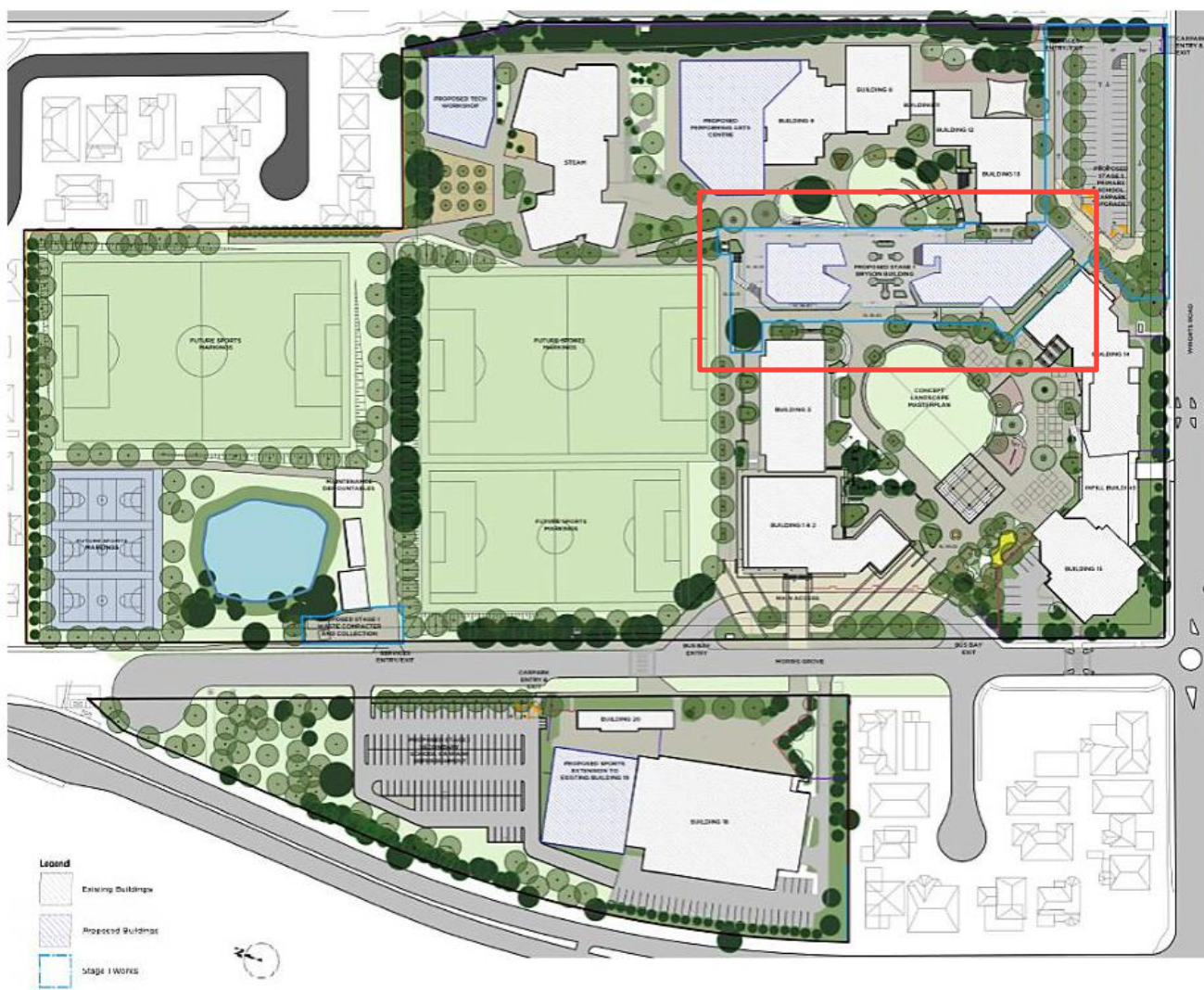

1.3 PURPOSE OF THIS PLAN

The CNVMP has been developed to satisfy the *Development Consent conditions, Application Number SSD 35715221, NSW Government, Department of Planning and Environment, 2023* relating to environmental noise and vibration.

The CNVMP aims to achieve the following:

- Identify the relevant legislative requirements
- Identify potential noise impacts and sensitive receivers associated with the project
- Identify potential vibration impacts associated with the project
- Outline systems and management measures to reduce or eliminate identified noise or vibration impacts
- Outline the responsibilities of those involved in the control of noise and vibration impacts
- Outline an effective monitoring, auditing and reporting framework to assess the effectiveness of the controls implemented.

Assessment within this document has been sourced from the *Noise & Vibration Impact Assessment, William Clarke College Kellyville Concept Masterplan & Stage 1 Works, (610.30786-R01-v1.1, SLR, August 2022)*

1.4 RELEVANT GUIDELINES

Noise and vibration guidelines for construction activities are based on publications managed by the New South Wales (NSW) Environment Protection Authority (EPA). The EPA guidelines applicable to this assessment include:

- *Interim Construction Noise Guideline* (Department of Environment and Climate Change (DECC), 2009), (ICNG)
- *Australian Standard 2436: 2010, Guide to noise and vibration control on construction, demolition and maintenance sites* (AS2436)
- *Assessing Vibration: a technical guideline* (DECC, 2006), (AVaTG)
- *British Standard 6472-1: 2008, Guide to evaluation of human exposure to vibration in buildings Part 1: Vibration sources other than blasting* (BS 6472-1, 2008)
- *German Standard 4150-3 Structural Vibration, Part 3: Effects of Vibration on Structures* (DIN 4150-3)
- *NSW Noise Policy for Industry* (EPA, 2017), (NPfI)
- *Construction Noise and Vibration Guideline (Roads)*, Transport for NSW, July 2023 (EMF-NV-GD-0056)

2 EXISTING NOISE ENVIRONMENT

2.1 SITE LOCATION AND IDENTIFIED SENSITIVE RECEIVERS

The project is located in a suburban area in Sydney's north-west. The site has frontage to Green Road, Wrights Road and Cormack Circuit, with vehicle access from Morris Grove and Wrights Road. The campus is bound by residential dwellings to the north, Wrights Road to the south, Cormack Circuit to the east and Green Road to the west. Residential dwellings are located further south of Wrights Road, east of Cormack Circuit and also bound the site to the southwest. Kellyville Village, a commercial shopping centre lies east of Green Road and approximately 200m southwest of the site boundary.

The existing noise environment at the site is generally influenced by road traffic from the surrounding road network with the nearest major road being Wrights Road, which bounds the southern site boundary. Other existing noise sources include children's play associated with WCC and environmental noise (birdlife)

The nearest sensitive receivers are residential dwellings located 15 m to the southwest and adjacent to the northern and north-eastern site boundary.

The receivers are grouped into Noise Catchment Areas (NCAs) based on their surrounding noise environment and sensitivity to noise and vibration. The study area includes all nearby locations that could be affected by noise and vibration from the proposed construction and operational activities at the Project. The identified NCAs and receivers help in understanding the potential impacts on these areas. Refer to the *Noise & Vibration Impact Assessment, William Clarke College Kellyville Concept Masterplan & Stage 1 Works, (610.30786-R01-v1.1, SLR, August 2022)*.

Figure 2.1 provides an indicative site map of the noise monitoring locations, NCAs, and noise-sensitive receivers within the assessment area.

Figure 2.1 Site Location, Surrounding Receivers and Noise Monitoring Locations (source, SLR Consulting)



2.2 BACKGROUND NOISE LEVELS

The existing noise environment is predominantly defined by road traffic along the surrounding road network. Other existing noise sources include children’s play associated with WCC and environmental noise (birdlife). The results of unattended noise monitoring have been sourced from the *Noise & Vibration Impact Assessment, William Clarke College Kellyville Concept Masterplan & Stage 1 Works, (610.30786-R01-v1.1, SLR, August 2022)*.

2.2.1 UNATTENDED NOISE SURVEYS

Unattended noise monitoring was conducted at the site from 22 March to 5 April 2024. Monitoring equipment was placed to measure noise levels representative of the most affected receivers. The equipment, certified and calibrated according to NATA standards, recorded noise levels continuously in 15-minute intervals throughout the day, evening, and night. The measured data has been processed to exclude noise from extraneous events and periods affected by adverse weather conditions, such as strong wind or rain, to establish representative existing noise levels in each NCA.

Table 2.1 presents the unattended monitoring results for the monitoring survey.

Table 2.1 Unattended noise monitoring results

ID	LOCATIONS	MEASURED NOISE LEVEL dBA					
		Background Noise (L ₉₀ , 15min)			Average Noise (L _{Aeq})		
		Day	Evening	Night	Day	Evening	Night
L1	Primary School Carpark (Southern Site Boundary)	37	40	35	53	54	45

ID	LOCATIONS	MEASURED NOISE LEVEL dBA					
		Background Noise (L ₉₀ , 15min)			Average Noise (L _{Aeq})		
		Day	Evening	Night	Day	Evening	Night
L2	Eastern Site Boundary (Opposite Building 8/11)	38	39	33	56	53	49
P1	Site boundary (Opposite 137 Wrights Road, Castle Hill)	40	41	31	53	50	46

Note: The assessment periods are the daytime which is 7 am to 6 pm Monday to Saturday and 8 am to 6 pm on Sundays and public holidays, the evening which is 6 pm to 10 pm, and the night-time which is 10 pm to 7 am on Monday to Saturday and 10 pm to 8 am on Sunday and public holidays. See the NSW EPA Noise Policy for Industry.

2.2.2 ATTENDED NOISE SURVEYS

Short-term attended noise monitoring was conducted at each location to identify the contributions of various noise sources. These measurements were generally consistent with the unattended noise monitoring results, indicating that existing noise levels are primarily influenced by road traffic from the surrounding network, with noise from children's play at the school contributing during the daytime.

3 CONSTRUCTION NOISE AND VIBRATION ASSESSMENT CRITERIA

3.1.1 DEVELOPMENT CONSENT CONDITIONS (APPLICATION NUMBER SSD 35715221)

The CNVMP will be prepared to comply with the *Development Consent conditions, Application Number SSD 35715221, NSW Government, Department of Planning and Environment, 2023*. The following conditions have been noted to specifically outline expectations for noise and vibration management:

C17. The Construction Noise and Vibration Management Sub-Plan (CNVMSP) must address, but not be limited to, the following:

- (a) be prepared by a suitably qualified and experienced noise expert:*
- (b) be consistent with recommendations in Stage 1 Works Noise and Vibration Impact Assessments dated 20 March 2023 and prepared by SLR Consulting Australia Pty Ltd:*
- (c) describe procedures for achieving the noise management levels in EPA's Interim Construction Noise Guideline (DECC, 2009).*
- (d) describe the measures to be implemented to manage high noise generating works such as piling, in close proximity to sensitive receivers.*
- (e) include strategies that have been developed with the community for managing high noise generating works.*
- (f) describe the community consultation undertaken to develop the strategies in Schedule 3 condition C17(e).*
- (g) include a complaints management system that would be implemented for the duration of the construction, and.*
- (h) include a program to monitor and report on the impacts and environmental performance of the development and the effectiveness of the management measures in accordance with Schedule 3 condition C13.*
- (...)*

Construction Hours

D5. Construction, including the delivery of materials to and from the site, may only be carried out between the following hours:

- (a) between 7am and 6pm, Mondays to Fridays inclusive; and*
- (b) between 8am and 1pm, Saturdays.*

No work may be carried out on Sundays or public holidays.

D6. Construction activities may be undertaken outside of the hours in Schedule 3 condition D5 if required:

- (a) by the Police or a public authority for the delivery of vehicles, plant or materials; or*
- (b) in an emergency to avoid the loss of life, damage to property or to prevent environmental harm; or*
- (c) where the works are inaudible at the nearest sensitive receivers; or*
- (d) where a variation is approved in advance in writing by the Planning Secretary or his nominee if appropriate justification is provided for the works.*

D7. Notification of such construction activities as referenced in Schedule 3 condition D6 must be given to affected residents before undertaking the activities or as soon as is practical afterwards.

D8. Rock breaking, rock hammering, sheet piling, pile driving, and similar activities may only be carried out between the following hours:

(a) 9am to 12pm, Monday to Friday.

(b) 2pm to 5pm Monday to Friday; and

(c) 9am to 12pm, Saturday.

(...)

Construction Noise Limits

D13. The development must be constructed to achieve the construction noise management levels detailed in the Interim Construction Noise Guideline (DECC, 2009). All feasible and reasonable noise mitigation measures must be implemented and any activities that could exceed the construction noise management levels must be identified and managed in accordance with the management and mitigation measures identified in the approved CNVMSP required by Schedule 3 condition C17.

D14. The Applicant must ensure construction vehicles (including concrete agitator trucks) do not arrive at the site or surrounding residential precincts outside of the construction hours of work outlined under Schedule 3 condition D5 unless approved by Schedule 3 condition D6.

D15. The Applicant must implement, where practicable and without compromising the safety of construction staff or members of the public, the use of 'quackers' to ensure noise impacts on surrounding noise sensitive receivers are minimised.

Vibration Criteria

D16. Vibration caused by construction at any residence or structure outside the site must be limited to:

(a) for structural damage, the latest version of DIN 4150-3 (1992-02) Structural vibration - Effects of vibration on structures (German Institute for Standardisation, 1999); and

(b) for human exposure, the acceptable vibration values set out in the Environmental Noise Management Assessing Vibration: a technical guideline (DEC 2006) (as may be updated or replaced from time to time).

D17. Vibratory compactors must not be used closer than 30m from residential buildings unless vibration monitoring confirms compliance with the vibration criteria specified in Schedule 3 condition D16.

D18. The limits in Schedule 3 condition D16 and Schedule 3 condition D17 apply unless otherwise outlined in a CNVMSP required by Schedule 3 condition C17.

3.2 CONSTRUCTION NOISE

The applicable assessment criteria for noise is found in the *Interim Construction Noise Guideline* (ICNG).

A quantitative assessment requires the development of noise management levels (NML) based on existing rating background noise levels (RBLs) and a comparison of predicted construction noise levels against the NML.

Recommended standard hours represent the times of the day when receivers are likely to be less sensitive to noise impacts. Where work is proposed outside of standard hours, justification is required and more stringent NMLs apply. For all other receiver types, the NMLs only apply when the receiver is typically occupied. Table 3.1 sets out the application of the management levels for noise at residences.

Table 3.1 Application of the ICNG noise management levels

SETTING AND APPLYING NMLS AT RESIDENCES		
TIME OF DAY	NML, $L_{eq,15min}$ dBA	HOW TO APPLY
Recommended standard hours: Monday to Friday 7 am to 6 pm Saturday 8 am to 1 pm No work on Sundays or public holidays	Noise affected RBL + 10 dB	The noise affected level represents the point above which there may be some community reaction to noise. Where the predicted or measured $L_{Aeq(15 min)}$ is greater than the noise affected level, the proponent should apply all feasible and reasonable work practices to meet the noise affected level. The proponent should also inform all potentially impacted residents of the nature of works to be carried out, the expected noise levels and duration, as well as contact details.
	Highly noise affected >75	The highly noise affected level represents the point above which there may be strong community reaction to noise. Where noise is above this level, the relevant authority may require respite periods by restricting the hours that the very noisy activities can occur, taking into account times identified by the community when they are less sensitive to noise and if the community is prepared to accept a longer period of construction in exchange for restrictions on construction times.
Outside recommended standard hours	Noise affected RBL + 5 dB	A strong justification would typically be required for works outside the recommended standard hours. The proponent should apply all feasible and reasonable work practices to meet the noise affected level. Where all feasible and reasonable practices have been applied and noise is more than 5 dB(A) above the noise affected level, the proponent should negotiate with the community.

It is noted that the working hours for construction of the project as contained within the consent condition are limited to the recommended standard hours. Exceptions to these hours are only allowed under the following circumstances:

- (a) by the Police or a public authority for the delivery of vehicles, plant or materials; or
- (b) in an emergency to avoid the loss of life, damage to property or to prevent environmental harm; or
- (c) where the works are inaudible at the nearest sensitive receivers; or
- (d) where a variation is approved in advance in writing by the Planning Secretary or his nominee if appropriate justification is provided for the works.

In consideration of the results of noise monitoring, Table 3.2 presents the NMLs for residential receivers and Table 3.3 for the nearest non-residential sensitive receivers.

Table 3.2 Noise management levels at residential receivers

NCA	MONITORING LOCATION	RESIDENTIAL NOISE MANAGEMENT LEVELS $L_{eq,15min}$ dBA			
		Standard Construction (RBL + 10 dB) ¹	Out of Hours (RBL + 5 dB)		
		Daytime	Daytime ²	Evening	Night-time
NCA01	L1	47	42	45	40
NCA02	L1	47	42	45	40
NCA03	L2	48	43	44	38
NCA04	P1	50	45	46	36
NCA05	L2	48	43	44	38

Note 1: RBL = Rating Background Level

Note 2: Daytime out of hours is 7 am to 8 am and 1 pm to 6 pm on Saturday, and 8 am to 6 pm on Sunday and public holidays

Table 3.3 Noise management levels for non-residential sensitive receivers

NCA	LAND USE	MANAGEMENT NOISE LEVEL (WHEN IN USE) $L_{EQ,15MIN}$ DBA	
		Internal	External
(R1)	Classrooms at schools and other educational institutions	45	55
(R2, R3)	Commercial	-	70
	Active Recreation (characterised by sporting activities and activities which generate noise)	-	65
	Passive recreation areas (characterised by contemplative activities that generate little noise)	-	60

Note 1: It is assumed that these receivers have windows partially open for ventilation which results in internal noise levels being around 10 dB lower than the external noise level.

Feasible and reasonable safeguards and management measures should be implemented where NMLs are exceeded either during or outside of recommended standard hours for construction work.

3.3 VIBRATION

Construction vibration is assessed for two potential impacts as follows:

- Cosmetic building damage
- Loss of amenity due to perceptible vibration, termed human comfort.

Importantly, cosmetic damage is regarded as minor in nature; it is readily repairable and does not affect a building's structural integrity. If there is no significant risk of cosmetic damage, then structural damage is considered highly unlikely.

3.3.1 COSMETIC BUILDING DAMAGE AND STRUCTURAL INTEGRITY

There are no vibration limits for buildings and structures in *Assessing Vibration: A Technical Guideline*. Therefore, the limits set out in British Standard BS 7358-2: *Evaluation and measurement for vibration in buildings guide to damage levels from ground-borne vibration* have been adopted.

A summary of the limits is provided in Table 3.4. These peak vibration limits are set so that the risk of cosmetic damage is minimal. They have been set at the lowest level above which damage has been credibly demonstrated. The limits also assume that the equipment causing the vibration is only used intermittently.

For heritage structures, different vibration limits may apply depending on the structural integrity or significance of the item.

Table 3.4 BS 7385-2 Guideline vibration limits for cosmetic damage

GROUP	TYPE OF STRUCTURE	PEAK COMPONENT PARTICLE VELOCITY, mm/s ¹		
		4–15 Hz	15–40 Hz	40 Hz AND ABOVE
1	Reinforced or framed structures Industrial or heavy commercial buildings	50		
2	Un-reinforced or light framed structures Residential or light commercial buildings	15 – 20 ²	20 – 50	50

Note 1: Values referred to are at the base of the building, on the side of the building facing the source of vibration (where feasible).

Note 2: At frequencies below 4 Hz, a maximum displacement of 0.6 mm (zero to peak) should not be exceeded.

3.3.1.1 HERITAGE STRUCTURES

Building structures classified as being of heritage significance are to be considered on a case-by-case basis, as a heritage listed structure may not be assumed to be more sensitive to vibration unless it is structurally unsound which is unlikely for a regularly maintained structure. Where a historic structure is deemed to be sensitive to damage from vibration following inspection by qualified structural and / or civil engineers, more conservative superficial cosmetic damage criterion based on peak component particle velocity (PPV) (German Standard DIN 4150-3: 1999 *Structural Vibration – Part 3: Effects of vibration on structures* or equivalent) should be considered.

Where a historic building is deemed to be sensitive to damage from vibration (structurally unsound), a conservative superficial cosmetic damage criterion of 3mm/s peak component particle velocity (based on DIN 4150) may be applicable.

It is noted that no vibration sensitive heritage structures have been identified in the vicinity of the project and as such, potential heritage impacts have not been assessed further. Should any heritage items be identified during the work, work

will cease until a determination of any impact can be made. These criteria should be applied to any assessment of impacts.

3.3.2 HUMAN COMFORT (AMENITY)

Table 3.5 presents the limits (vibration dose values) above which there is considered to be a risk that the amenity and comfort of people occupying buildings would be affected by intermittent vibration from construction works. These limits are taken from Assessing Vibration: A Technical Guideline.

Table 3.5 Human comfort (amenity) guideline vibration limits (intermittent work)

LOCATION	ASSESSMENT PERIOD	VIBRATION DOSE VALUE, $m/s^{1.75}$	
		PREFERRED VALUES	MAXIMUM VALUES
Critical areas	Day or nighttime	0.10	0.20
Residences	Daytime	0.20	0.40
	Nighttime	0.13	0.26
Offices, schools, educational institutions, and places of worship	Day or nighttime	0.40	0.80
Workshops	Day or nighttime	0.80	1.60

3.4 CONSTRUCTION TRAFFIC

The Road Noise Policy (RNP) provides guidance on the assessment of noise impacts from road traffic noise on sensitive receiver types.

The RNP application notes state that ‘for existing residences and other sensitive land uses affected by additional traffic on existing roads generated by land use developments, any increase in the total traffic noise level as a result of the development should be limited to 2 dBA above that of the noise level without the development. This limit applies wherever the noise level without the development is within 2 dBA of, or exceeds, the relevant day or night noise assessment criterion.’

The RNP criteria apply to traffic generated by construction activities. The existing roads immediately surrounding the project site are classified as arterial and sub-arterial. Arterial, sub-arterial and collector roads are assessed over day (7 am-10 pm) and night (10 pm-7 am) periods and local roads are assessed over a one-hour period (typically the peak hour) within the respective day and night periods. Table 3.6 presents a summary of the applicable criteria for residences.

Table 3.6 Road traffic noise criteria for residential receivers on existing roads affected by additional traffic from land use developments

ROAD TYPE	ROAD TRAFFIC	NOISE CRITERIA
	DAY	NIGHT
Arterial/Sub-arterial/Collector	60 L_{eq} 15hr dBA	55 L_{eq} 9hr dBA
Local Road (Newington Road)	55 L_{eq} 1hr dBA	50 L_{eq} 1hr dBA

Where the road traffic noise levels increase by more than 2 dBA as a result of the proposed construction traffic and the criteria in Table 3.6 are exceeded, investigation of mitigation options would be required.

4 ASSESSMENT OF NOISE AND VIBRATION IMPACTS

4.1 CONSTRUCTION ACTIVITIES

The work will be completed in stages comprising different activities. Within each stage, the item of equipment with the greatest potential to generate noise impacts has been assessed. Table 4.1 presents the assessed activities, equipment, and total sound power levels for each construction stage according to the *Noise & Vibration Impact Assessment, William Clarke College Kellyville Concept Masterplan & Stage 1 Works, (610.30786-R01-v1.1, SLR, August 2022)*. In accordance with the commissioned WSP scope of works, no additional assessment has been undertaken.

Table 4.1 Construction activities (Source SLR)

Construction scenario	Plant and equipment	Sound Power Level dBA per source	Sound Power Level dBA total per scenario
1 - Site Establishment	Crane (60 tonne)	100	115
	Excavator (22 tonne)	100	
	Grader	113	
	Hand Tools	94	
	Power Auger	103	
	Vibratory Roller (12 tonne)	109	
	Truck (10 tonne)	108	
2 – Groundworks and Substructure (Primary Carpark)	Excavator (22 tonne)	100	115
	Grader	113	
	Mobile Crane (22 tonne)	98	
	Vibratory Roller (12 tonne)	109	
3 – Ground works and Substructure (Byron Building)	Concrete Agitator	109	116
	Concrete Pump	106	
	Concrete Vibrator	113	
	Crane (60 tonne)	100	
	Excavator (22 tonne)	100	
	Hand Tools	94	
	Pilling Rig (Bored)	111	
	Truck (10 tonne)	108	
4 – Structure	Concrete Agitator	109	114

Construction scenario	Plant and equipment	Sound Power Level dBA per source	Sound Power Level dBA total per scenario
(Byron Building)	Concrete Pump	106	
	Concrete Vibrator	113	
	Crane (60 tonne)	100	
	Power generator (Site compounds)	103	
	Hand Tools	94	
	Truck (10 tonne)	108	
5-Cladding and Roofing (Byron Building)	Crane (60 tonne)	100	104
	Hand Tools	94	
	Forklift	101	
6- Internal Services & Finishes (Byron Building)	Crane (60 tonne)	100	107
	Hand Tools	94	
	Truck (10 tonne)	108	
	Elevated Working Platform	94	

HOURS OF CONSTRUCTION

Construction activities would be undertaken during the working hours defined in the *Development Consent conditions, Application Number SSD 35715221, NSW Government, Department of Planning and Environment, 2023* as follows:

D5. Construction, including the delivery of materials to and from the site, may only be carried out between the following hours:

- (a) between 7am and 6pm, Mondays to Fridays inclusive; and*
- (b) between 8am and 1pm, Saturdays.*

No work may be carried out on Sundays or public holidays.

D8. Rock breaking, rock hammering, sheet piling, pile driving, and similar activities may only be carried out between the following hours:

- (a) 9am to 12pm, Monday to Friday.*
- (b) 2pm to 5pm Monday to Friday; and*
- (c) 9am to 12pm, Saturday.*

Any works outside of these hours will be approved by SOPA and community / neighbour notification will occur at least 24 hours in advance.

4.2 ASSESSMENT METHOD

The *Noise & Vibration Impact Assessment, William Clarke College Kellyville Concept Masterplan & Stage 1 Works, (610.30786-R01-v1.1, SLR, August 2022)* outlines the assessment of potential impacts during construction works. The

construction noise and vibration assessment is relative to the S1W only, which includes the construction of The Bryson Building and the Primary School Car Park, as well as the relocation of the waste compound.

Local terrain, receiver buildings and structures were digitised in the noise model to develop a three-dimensional representation of the construction sites and surrounding areas.

Construction modelling was undertaken using model parameters consistent with operational noise modelling for typical day time neutral conditions with the ISO 9613-2 industrial noise algorithm in noise Version 2021.11.

The assessment uses ‘realistic worst-case’ scenarios to determine the impacts from the noisiest 15-minute period that are likely to occur for each work scenario, as required by the ICNG. The impacts represent construction noise levels without mitigation applied.

4.3 PREDICTED NOISE LEVELS

Table 4.2 presents the predicted number of NCA exceedances for each assessed construction scenarios compared to the relevant NMLs.

Table 4.2 Predicted number of residential exceedances for each construction stage

NCA/ID	Type	NML	Predicted Noise Level – $L_{ae}(15\text{minute})$ (dBA)					
			Preliminary Works	Groundworks & Structure (Carpark)	Groundworks & Structure (Bryson)	Structure (Bryson)	Cladding & Roofing (Bryson)	Internal Services & Finishes (Bryson)
NCA01	Residential	47	65	38	65	64	53	50
NCA02		47	68	78	68	67	55	53
NCA03		48	57	66	57	56	53	53
NCA04		50	56	38	56	55	51	51
NCA05		48	49	34	49	48	44	44
R01	Educational Facility1	55	63	41	63	62	51	49
R02	Commercial	70	53	64	53	52	46	46
R03	Commercial	70	53	34	53	52	42	41

1. Educational NML Criteria is only applicable when receiver is in use.
2. **Green shaded cells** indicated predicted noise levels exceed the daytime NMLs at this NCA.

4.4 DISCUSSION

In summary, construction noise levels are predicted to:

- Comply with the Noise Management Levels for all scenarios at R01 with the exception of the ‘Preliminary Works,’ ‘Groundworks and Substructure’ and ‘Structure’ scenario relative to the Bryson Building.
- Comply with the Noise Management Levels at R02 for all construction scenarios
- Exceed the Noise Management Levels at NCA02 and NCA03 for all construction scenarios.
- Exceed the Noise Management Levels at NCA01 and NCA04 for all construction scenarios with the exception of the ‘Groundworks and Substructure’ scenario relative to the Primary Carpark.
- Comply with the Noise Management Levels for all scenarios at NCA05 with the exception of the ‘Preliminary Works’ and the ‘Groundworks and Substructure’ scenario relative to the Bryson Building.
- No exceedances of highly noise affected NMLs or non-residential NMLs have been predicted.

As exceedances of NMLs have been predicted, noise management measures have been provided in Section 5.

4.5 VIBRATION ASSESSMENT

Certain construction activities would require the use of vibration intensive equipment that may affect the nearest sensitive receivers. The major potential sources of vibration from the proposed construction activities would likely be during ‘Preliminary Works’ and ‘Groundworks and Substructure’ when vibratory rollers are being used.

Minimum working distances for typical vibration intensive construction equipment are provided in the Roads and Maritime (now Transport for NSW) Construction Noise and Vibration Guideline (CNVG) and are shown in Table 4.3. The minimum working distances are for both cosmetic damage (from BS 7385 and DIN 4150) and human comfort (from the NSW EPA Vibration Guideline). They are based on empirical data which suggests that where works are further from receivers than the quoted minimum distances then impacts are not considered likely.

The minimum working distances are indicative and will vary depending on the particular item of equipment and local geotechnical conditions. The distances apply to cosmetic damage of typical buildings under typical geotechnical conditions.

Table 4.3 Recommended minimum working distances for vibration intensive plant

PLANT ITEM	RATING/ DESCRIPTION	MINIMUM WORKING DISTANCE	
		Cosmetic damage residential and light commercial (BS 7385)	Human comfort (NSW EPA guideline)
Vibratory Roller	<50 kN (1–2 tonne)	5 m	15 m to 20 m
	<100 kN (2–4 tonne)	6 m	20 m
	<200 kN (4–6 tonne)	12 m	40 m
	<300 kN (7–13 tonne)	15 m	100 m
	>300 kN (13–18 tonne)	20 m	100 m
	>300 kN (>18 tonne)	25 m	100 m

Two residential properties near the proposed work site are within the minimum working distance for cosmetic damage when vibration intensive works are being conducted in the Primary Carpark, however it is noted that vibratory roller activity will be intermittent in nature and not continuous. These properties are:

- 152 Wrights Road, Kellyville
- 28 Cormack Circuit, Kellyville

The distance between the construction works and all other sensitive receivers is sufficient for receiver buildings to be outside of the cosmetic damage minimum working distance for vibration intensive equipment.

Residential buildings shown in Figure 4.1 Human Comfort minimum offset distance are within the human comfort minimum working distance and occupants of these buildings may be able to perceive vibration impacts at times when vibratory rollers are in use nearby. Where impacts are perceptible, they would likely only be apparent for relatively short durations when vibration intensive equipment is in use.

Figure 4.1 Human Comfort minimum offset distances



4.6 TRAFFIC ASSESSMENT

Section 10 of the Construction Management Plan (EIS Appendix FF) issued by Rohrig on 26 September 2022 states the following:

All construction traffic, temporary roads and storage of materials will occur within the site. All construction traffic will be advised to use Morris Grove. Once the Primary Carpark is ready to be completed, access from the South will be created.

(...)

The construction is likely to generate in any one day at its peak of up to 30 truck movements (15 in and 15 outbound), this is during concrete pours. Throughout the construction, the average number of daily construction vehicles onsite

- *Enabling works – 20 truck movements (10 in and 10 outbound)*
- *General construction - 30 truck movements (15 in and 15 outbound)*
- *Fitout - 30 truck movements (15 in and 15 outbound)*
- *Landscaping works - 20 truck movements (10 in and 10 outbound)*

The contractor is likely to require a on average 30-40 staff per day, with a maximum of 60 staff on a day. To accommodate this number of workers, on average there would be up to 30 light vehicles on site, whilst at the maximum there would be 50 light vehicles on site.

Moreover, construction vehicle access will be restricted during school terms at the following times.

- 7:45am – 8:45am Monday – Friday
- 2:45pm – 3:45pm Monday – Friday

Existing road traffic movements are not known. As construction road traffic inputs are not assessed within the *Noise & Vibration Impact Assessment, William Clarke College Kellyville Concept Masterplan & Stage 1 Works, (610.30786-R01-v1.1, SLR, August 2022)* it is assumed that no impacts have been predicted.

5 NOISE AND VIBRATION MANAGEMENT MEASURES

5.1 INTRODUCTION

The assessment outlined in Section 4 has predicted NML exceedances throughout the duration of the works. No exceedances of highly noise affected NMLs have been predicted.

No exceedances of road traffic noise are expected to occur.

Exceedances of human comfort ground vibration minimum working distances are expected to occur

As such, suitable site-specific measures have been assessed to reduce the exceedance of NMLs during construction works.

5.2 NOISE MANAGEMENT

The *Noise & Vibration Impact Assessment* recommends consideration of the Transport of NSW 2018 Construction Noise and Vibration Strategy (CNVS), which provides further guidance on appropriate noise mitigation options depending on the level of exceedance predicted (refer Section 4.3). The recommended triggers for additional mitigation measures are shown in Table 5.1.

Table 5.1 Recommended Triggers for Additional Mitigation Measures – Airborne Noise

	dB(A) ABOVE NML	ADDITIONAL MITIGATION MEASURE
STANDARD HOURS: MON - FRI (7AM – 5:30PM), SAT (8AM – 1PM), SUN/PUB HOLIDAY (NIL)		
Noticeable	0	-
Clearly audible	<10	-
Moderately intrusive	10 to 20	PN, V
Highly intrusive	> 20	PN, V
75dB(A) or greater	-	PN, V, SN

PN = Project notification

V = Verification monitoring

SN = Specific Notification, individual briefings or phone call

As such, the following measures are recommended to be employed at the locations identified in Section 4.3:

- Verification monitoring
- Project Notification
- Specific Notification

5.3 MANAGEMENT MEASURES

The noise mitigation and management measures outlined in Table 5.2 will be implemented to reduce the predicted noise impacts.

Table 5.2 Management controls

CONDITION	TYPE OF ACTION	MANAGEMENT MEASURE	APPLIES	PROJECT STAGE	RESPONSIBILITY
N1	Construction hours and scheduling	Construction should be carried out during the standard daytime working hours. Work generating high noise and/or vibration levels should be scheduled during less sensitive time periods.	Noise	Planning	Contractor
N2	Implement community consultation measures	Community information leaflets about the works and activities should be prepared regarding potential noise impacts, and letter box dropped to potentially impacted sensitive receivers. This information should include the expected level and duration of noise impact, as well as contact details for a construction community liaison officer. Notification should be a minimum of 7 calendar days prior to the start of works. For most impacted receivers individual contact may be required.	Noise	Planning	Contractor
N3	Training	All employees, contractors and subcontractors are to receive an environmental induction. The induction must at least include: <ul style="list-style-type: none"> — all project specific and relevant standard noise and vibration mitigation measures — relevant licence and approval conditions — permissible hours of work — any limitations on high noise generating activities — location of nearest sensitive receivers — construction employee parking areas — designated loading/unloading areas and procedures — site opening/closing times (including deliveries) — environmental incident procedures. 	Noise	Planning	Contractor
N4	Behavioural practices	No swearing or unnecessary shouting or loud stereos/radios on site. No dropping of materials from height, throwing of metal items and slamming of doors.	Noise	Construction	Contractor
N5	Monitoring	Noise verification is to be carried out during early stages of construction to verify the predictions within the Noise and vibration assessment. Refer Section 6.2 for methodology.	Noise	Construction	Contractor
N6	Monitoring	At the commencement of vibratory compaction, attended vibration measurements should be undertaken at to confirm that vibration levels are within the acceptable range to prevent	Noise	Construction	Contractor

CONDITION	TYPE OF ACTION	MANAGEMENT MEASURE	APPLIES	PROJECT STAGE	RESPONSIBILITY
		cosmetic building damage. This should be undertaken at the properties outlined in Section 4.5. Refer Section 6.2 for methodology.			
N7		Undertake building dilapidation surveys on all buildings located within the identified buffer zone (refer Section 4.5) prior to commencement of activities with the potential to cause property damage	Noise	Planning	Contractor
N8	Plant and equipment	The noise levels of plant and equipment items are to be considered during the selection of plant. The noise levels of plant and equipment must have operating Sound Power or Sound Pressure Levels compliant with the criteria in Appendix H of the CNVG. Implement a noise monitoring audit program to ensure equipment remains within the more stringent of the manufacturer's specifications or Appendix H of the CNVG.	Noise	Planning	Contractor
N9	Plan worksites and activities to minimise noise and vibration	Plan traffic flow, parking and loading/unloading areas to minimise reversing movements within the site. Forward-in / forward-out movements are preferred.	Noise	Planning	Contractor
N10		Quieter construction methods will be used where feasible and reasonable Simultaneous use of noisy equipment should be avoided where reasonable and feasible.	Noise	Planning and Construction	Contractor
N11	Complaint record management	Recording and managing any complaints in accordance with the procedure set out in the project Environmental Management Plan.	Noise	Planning and Construction	Contractor
N12	Maintenance of plant	All plant and tools are to be regularly maintained and checked to ensure that they are running correctly and not producing excessive noise emissions — Periodic inspection of equipment shall be conducted to ensure that they have been maintained correctly and are not generating excessive noise and vibration	Noise	Construction	Contractor
N13	Compression Brakes	Truck drivers will limit compression braking as far as practicable	Noise	Construction	Contractor

6 COMPLIANCE MANAGEMENT

6.1 TRAINING

All employees, contractors and utility staff working on site will undergo site induction training relating to environmental issues, including noise and vibration management. The induction training will address the following elements related to noise and vibration management:

- The existence and requirements of this sub-plan
- Work hours and the requirement for strict compliance
- Delivery hours, trucking routes and loading / unloading locations
- Noise mitigation measures
- Project environmental responsibilities
- Location of sensitive noise receivers
- The importance of regular plant maintenance.

Records would be kept of all personnel undertaking the site induction and training, including the contents of the training, date and name of trainer/s in accordance with Section 6.6.

Key staff will undertake more comprehensive training relevant to their position and/or responsibility. This training may be provided as “toolbox” training or at a more advanced level by the Environmental or Safety Manager or delegated representatives.

6.2 MONITORING

Construction noise and vibration levels will be monitored at locations representative of impacted properties in response to complaints and at the commencement of construction activities to verify compliance with the noise and vibration objectives identified in Section 3.

Environmental monitoring will be conducted by a qualified acoustic specialist and in accordance with *AS1055-2018: Acoustics - Description and measurement of environmental noise* (AS1055-2018), ICNG, AVaTG and NPfI guidelines. The results of monitoring will include:

- Date, time and location of monitoring
- Name of person conducting the monitoring
- Relevant statistical descriptors to be recorded. For example, 15-minute intervals including L_{Aeq} , L_{AMax} and L_{A90} levels and the primary noise sources contributing to each statistic
- Noise instrumentation to be fitted with wind shields, and calibrated prior to measurements to measure drift
- Vibration instrumentation to be appropriately installed
- Details of site activity, environmental noise characteristics and weather to be noted
- Where required, noise monitoring of mobile plant to be carried out in accordance with AS2102.1 1990 *Acoustics- Measurement of airborne noise emitted by earth-moving machinery and agricultural tractors-stationary test conditions*

- Noise instrumentation to comply with the requirements of *AS 1259.2-1990. “Acoustics- Sound Level Meters, Part 2- Integrating and Averaging”* and carry appropriate NATA certification.

All records are to be kept in accordance with Section 6.6 and will be produced to any authorised officer upon request.

Where monitoring indicates exceedances of the project construction noise criteria outlined in Section 3, the non-conformance procedures outlined in Section 6.5 shall be followed.

6.3 COMPLAINTS MANAGEMENT

Noise complaints will be taken seriously and dealt with expeditiously. Each complaint will be investigated and where the noise in question is in excess of allowable limits, appropriate noise amelioration measures put in place to mitigate future occurrences.

Complaints will generally be managed in accordance with the *Better Practice Guide to Complaint Handling* (Australian Government, Commonwealth Ombudsman, 2009) and Australian Standard 10002-2006 *Customer Satisfaction— guidelines for complaints handling in organizations* (AS ISO 10002, 2006) with noise complaints being able to be lodged via a website and a phone hotline. The CEMP contains detail of the complaints handling process.

6.4 INSPECTIONS AND AUDITING

Audits (both internal and external) may be undertaken to assess the effectiveness of environmental controls, compliance with this sub plan and other relevant approvals, licences and guidelines.

6.5 NON-COMPLIANCES

All results of noise and vibration monitoring will be recorded and reviewed by the Contractor and site manager. Issues of concern or non-compliance will be documented and discussed with the site manager with the view of resolving the issue or determining a way forward. William Clarke College will be informed of all non-compliances.

Where identified exceedances may impact the safety of people or property, work at the concerned site shall cease immediately. Typical emergency situations that may result in substantial noise and/or vibration impacts may include substantial noise events during out of hours works or vibration causing significant structural damage to nearby buildings. These events are considered highly unlikely, however in the event of such an event occurring:

- 1 Work would cease immediately
- 2 Any occupants would be evacuated with due consideration to safety
- 3 The area would be secured to prevent unauthorised access
- 4 A structural assessment would be undertaken, and the results compared with any previous dilapidation survey
- 5 Where the damage is associated with construction, rectification work would be implemented, or compensation agreed.

An Environmental Incident Report form would be completed by the Contractor for any incident causing a noise and / or vibration impact on local residences. This form should identify the cause of the incident, the investigation of corrective actions and close out of the problem.

6.6 REPORTING

Records relating to noise and vibration on the project shall be maintained for a period of four years in the site Environmental register or equivalent. These records shall include details related to noise and vibration management, including:

- Training / inductions records
- Equipment inspections
- Noise or vibration monitoring reports
- Audit or reviews
- Communication regarding noise management
- Details of complaints

6.7 PLAN REVIEW

Continual improvement of this plan will be achieved by the continual evaluation of environmental management performance against proposed control measures, environmental policies, objectives and targets for the purpose of identifying opportunities for improvement.

The continual improvement process will be designed to:

- Identify areas of opportunity for improvement of environmental management which leads to improved environmental performance
- Determine the root cause or causes of non-conformances and deficiencies
- Develop and implement a plan of corrective and preventative action to address non-conformances and deficiencies
- Verify the effectiveness of the corrective and preventative action
- Document any changes in procedures resulting from process improvement
- Make comparisons with objectives and targets.

Changes to this plan will be approved by the contractor and stakeholders (if required) and documented in the document control section for each revision. A copy of the updated plan and changes will be distributed to all relevant stakeholders.



Rohrig Constructions

September 2024

Construction Traffic and Pedestrian Management Sub Plan

William Clarke College



Question today *Imagine tomorrow* Create for the future

Construction Traffic and Pedestrian Management Sub Plan William Clarke College

Rohrig Constructions

WSP
Level 27, 680 George Street
Sydney NSW 2000
GPO Box 5394
Sydney NSW 2001

Tel: +61 2 9272 5100
Fax: +61 2 9272 5101
wsp.com

Rev	Date	Details
	05/09/2024	Preliminary Draft – client review
	07/09/2024	Draft

	Name	Date	Signature
Prepared by:	C Chun	06/09/2024	
Reviewed by:	R Miller	06/09/2024	
Approved by:	S Longman	06/09/2024	

WSP acknowledges that every project we work on takes place on First Peoples lands.
We recognise Aboriginal and Torres Strait Islander Peoples as the first scientists and engineers and pay our respects to Elders past and present.

This document may contain confidential and legally privileged information, neither of which are intended to be waived, and must be used only for its intended purpose. Any unauthorised copying, dissemination or use in any form or by any means other than by the addressee, is strictly prohibited. If you have received this document in error or by any means other than as authorised addressee, please notify us immediately and we will arrange for its return to us.

Table of contents

1	Introduction	1
1.1	Project description	1
1.2	Study area	2
1.3	Scope and purpose of this plan	3
1.3.1	Department of Planning and Environment Conditions	4
1.3.2	Transport for NSW Advice	4
1.3.3	The Hills Shire Council Advice.....	4
1.4	Site inspection	5
1.5	Reference documents	5
2	Existing conditions	6
2.1	School access plan	6
2.2	School operational hours	8
2.3	School pick-up and drop-off.....	9
2.4	Road network	10
2.4.1	Intersection performance	10
2.5	Public transport	11
2.6	Pedestrians and cyclists.....	13
2.7	Parking.....	14
3	Proposed Stage 1 project	16
3.1	Description of construction activities	16
3.2	Timing and hours of works.....	18
3.3	Construction methodology.....	18
3.3.1	Site access, site establishment, fencing & hoardings	18
3.3.2	Site compound.....	18
3.3.3	Works zone.....	19
3.3.4	Deliveries and material handling.....	19
3.3.5	Concrete pumping	19
3.3.6	Cranage.....	19
3.3.7	Rubbish removal.....	19
3.4	Construction traffic	20
3.4.1	Construction vehicle volumes and types.....	20
3.4.2	Construction vehicle routes and site access.....	20
3.4.3	Construction plant and equipment	21
3.4.4	Driver code of conduct.....	22

3.5	Construction traffic management	22
3.5.1	Construction vehicles.....	22
3.5.2	Cyclists and pedestrians.....	22
3.5.3	Public transport.....	23
4	Impacts of the proposed works	24
4.1	Impacts to traffic.....	24
4.2	Impacts to pedestrians and cyclists.....	24
4.3	Impacts to public transport	24
4.4	Impacts to parking.....	24
4.5	Impacts to emergency vehicle access	25
5	Mitigation measures	26
5.1	Road safety	26
5.1.1	Pedestrian management.....	26
5.1.2	Signage	26
5.1.3	Parking	26
5.2	Traffic control	26
5.3	Traffic Guidance Schemes	28
5.4	Stakeholder consultation	28

List of tables

Table 2.1	SIDRA modelling output	10
-----------	------------------------------	----

List of figures

Figure 1.1	Approved Stage 1 works at William Clarke College (note Carpark and waste compound not included in this scope).....	2
Figure 1.2	Aerial view of the project site (William Clarke College, Kellyville)	3
Figure 2.1	School access plan showing school gate locations	6
Figure 2.2	School access gate no 4 for pedestrians off Wrights Road.....	7
Figure 2.3	School access gate no 14 proposed for construction vehicle and construction staff access off Morris Grove.....	8
Figure 2.4	Existing school pick-up and drop-off spaces	9
Figure 2.5	Existing bus stops near the Subject site	12
Figure 2.6	Private and school buses service	12

Figure 2.7	Existing public bus service	13
Figure 2.8	Existing shared paths	14
Figure 2.9	Existing parking provision.....	15
Figure 3.1	Construction activities Stage 1 (note carpark and waste compound not included in this scope or plan)	16
Figure 3.2	Construction traffic access routes.....	21
Figure 5.1	Traffic control required on Morris Grove near Wrights Road intersection.....	27
Figure 5.2	Traffic control required on Morris Grobe near Gate 14	28

DRAFT

1 Introduction

1.1 Project description

William Clarke College plans to redevelop the area surrounding and including buildings 6 and 7 within its current campus at 1 Morris Grove, Kellyville. Established in 1988, the College expanded its buildings and facilities to accommodate a growing student population drawn from Kellyville, The Hills Local Government Area, and other parts of north-western Sydney. The College currently serves 1,907 students, with enrolment projected to increase by 10% to 2,100 students in the near future. As part of the Stage 1 development works, the construction of the Bryson building will be undertaken by Rohrig Constructions.

Note the approved works to upgrade the waste collection site, and the upgrade of the existing primary school car park, as shown in Figure 1.1 are not included in this scope of works, or this plan.

Rohrig Constructions has engaged WSP to prepare the Construction Traffic and Pedestrian Management Sub-plan (CTPMSP) for the Byron building construction at William Clarke College (the Subject site). This report assesses the potential impacts on traffic, pedestrians, cyclists, and access during the construction period and provides mitigation measures where necessary. Specifically, the report covers the following:

- Review of existing traffic volumes, public transport, parking, pedestrian and cyclist conditions adjacent to the subject site
- Description of the proposed project
- Identification of proposed travel routes for construction traffic
- Review of operating conditions and expected impacts for all road users during the works period
- Provision of suggested mitigation measures to address project-related impacts.



Figure 1.1 Approved Stage 1 works at William Clarke College (note Carpark and waste compound not included in this scope)

1.2 Study area

The site is located within the Hills Shire Council Local Government Area (LGA) in the eastern part of Kellyville. It is approximately 2 km north-east of the Norwest business and employment area, 1.5 km north of the Castle Hill industrial area, and 4 km north of Castle Towers shopping centre. Approximately 350 metres to the west, across Green Road, lies Kellyville Village shopping centre.

The site is surrounded by residential developments to the north, east, and south. To the west, there is a mix of residential and business properties, including a kindergarten, a dental practice, open space, and Kellyville Village. The site fronts Green Road to the west, Cormack Circuit to the east, and Wrights Road to the south, with Morris Grove running north-south within the school grounds.



Figure 1.2 Aerial view of the project site (William Clarke College, Kellyville)

1.3 Scope and purpose of this plan

This Construction Traffic and Pedestrian Management Sub-Plan (CTPMSP) has been prepared as a requirement of consent conditions from the Department of Planning and Environment. The specific requirements of this plan and its objectives are further documented in section 1.3.1 following, with primary purpose around road safety and network

efficiency. The scope of this plan also considers agency comments received from both Transport for NSW and The Hills Shire Council where deemed required for the CTPMP and not the TIA (which was the document assessed which comments refer to). These requirements are documented in sections 1.3.2 and 1.3.3 following.

The CTPMP will be reviewed promptly where any site operations assumed in this report are modified to ensure the CTPMP remains up to date.

1.3.1 *Department of Planning and Environment Conditions*

C16. The Construction Traffic and Pedestrian Management Sub-Plan (CTPMSP) must be prepared to achieve the objective of ensuring safety and efficiency of the road network and address, but not be limited to, the following:

- (a) be prepared by a suitably qualified and experienced person(s);
- (b) be consistent with the Section 9 - Construction Pedestrian and Traffic Management Plan Methodology (Stage 1) in the Traffic Impact Assessment prepared by Ptc dated 27 June 2023;
- (c) be prepared in consultation with Council and TfNSW;
- (d) detail the measures that are to be implemented to ensure road safety and network efficiency during construction in consideration of potential impacts on general traffic, cyclists and pedestrians and bus services; and
- (e) detail heavy vehicle routes, access and parking arrangements.

1.3.2 *Transport for NSW Advice*

16 December 2022

A Construction Traffic and Pedestrian Management Plan (CTMP) must be prepared prior to the issue of the construction certificate with details of predicted construction traffic movements, routes and access arrangements, and outline how construction traffic impacts on existing traffic, pedestrian and cycle networks would be appropriately managed and mitigated.

1.3.3 *The Hills Shire Council Advice*

9 December 2022

Parking and Traffic

- Concerns are raised with allowing right turn movements from Wrights Road into the proposed redeveloped car park as it may result in queuing on La Vista Grove/Wright's Road thereby impacting residents access. Further queuing may result in Kings Road/Emily Clarke Dr intersection being impacted and therefore Sidra Modelling should be undertaken at these key intersections.
- The Traffic report identifies a LOS of F at the intersection of Wrights Road/Green Road intersection. Council strongly advises consideration towards a left in left out arrangement onto Green Road from Morris Grove as this would significantly alleviate traffic flow.

11 August 2023

Parking layout and traffic issues

- Carpark layout driveways, and aisles are to be designed according to the relevant Australian Standards. AS/NZS 2890.1:2004, AS 2890.2-2002 and AS/NZS 2890.6:2009. All dimensions are to be clearly labelled on the plans. Plans should also clearly identify if they are dedicated to visitor or staff. All dimensions are to be detailed on the plan including the parking spaces relevant to the user classification.
- Vehicles shall be able to enter and leave the site in a forward direction.

- Submit swept turning paths demonstrating the required manoeuvring in order for longest vehicle to enter and leave the site in a forward direction.
 - The driveway width must be designed to facilitate expected longest vehicle type and a B99 car pass each other simultaneously (i.e. maintaining two-way traffic flow).
-

1.4 Site inspection

A site inspection was conducted on Tuesday 3rd September 2024 at 4.30-5.30pm to better understand existing access, road and traffic conditions for all road users. The site inspection was limited to the public footpath area only. No access to private or school grounds were completed. Photos of site access, road network, intersections and parking locations were captured. Some of these photos have been included in this plan for guidance purposes for gate access.

1.5 Reference documents

In the preparation of this CTPMP report, the following documents have been referenced:

- William Clarke College Traffic impact assessment, Revision 4 (27 June 2023, ptc)
- Construction Management Plan, Stage 1 works – Bryson Building, Primary Carpark and Waste Compound (27 September 2022, Rohrig Constructions)
- Development Consent conditions for Application number SDD-35715221 (20 October 2023, Department of Planning and Environment)
- Agency letters from TfNSW and the Hills Shire Council as part of the Response to Submissions (RTS).

2 Existing conditions

2.1 School access plan

The existing school accesses are shown in Figure 2.1 below. This figure gives a good indication of access and those likely to be used during construction of Stage 1 of the project. The plan assists in determining the various users by access gate or location which may include pedestrians, bus passengers, buses, light vehicles.

Gates 14 would be the primary construction vehicle and construction staff access for Stage 1 project construction.



Source: William Clarke College Traffic Impact Assessment (PTC, June 2023)

Figure 2.1 School access plan showing school gate locations



Figure 2.2 School access gate no 4 for pedestrians off Wrights Road



Figure 2.3 School access gate no 14 proposed for construction vehicle and construction staff access off Morris Grove

2.2 School operational hours

The current school operating hours at William Clarke College are as follows:

The college is open for student arrivals from 7am and the finish times are staggered

- Prep Start 8:30am Finish 2:45pm
- K to Yr2 Start 8:30am Finish 3:00pm
- Yr3 to Yr6 Start 8:30am Finish 3:10pm
- Secondary Start 8:30am Finish 3:25pm.

2.3 School pick-up and drop-off

William Clarke College currently has 28 pick-up and drop-off spaces. The existing pick-up and drop-off zone locations are shown in Figure 2.4. There are 20 spaces provided along the driveway off Morris Grove, accessible via Gate 12, and eight spaces located north of the existing primary school car parks, accessible via Gate 4.

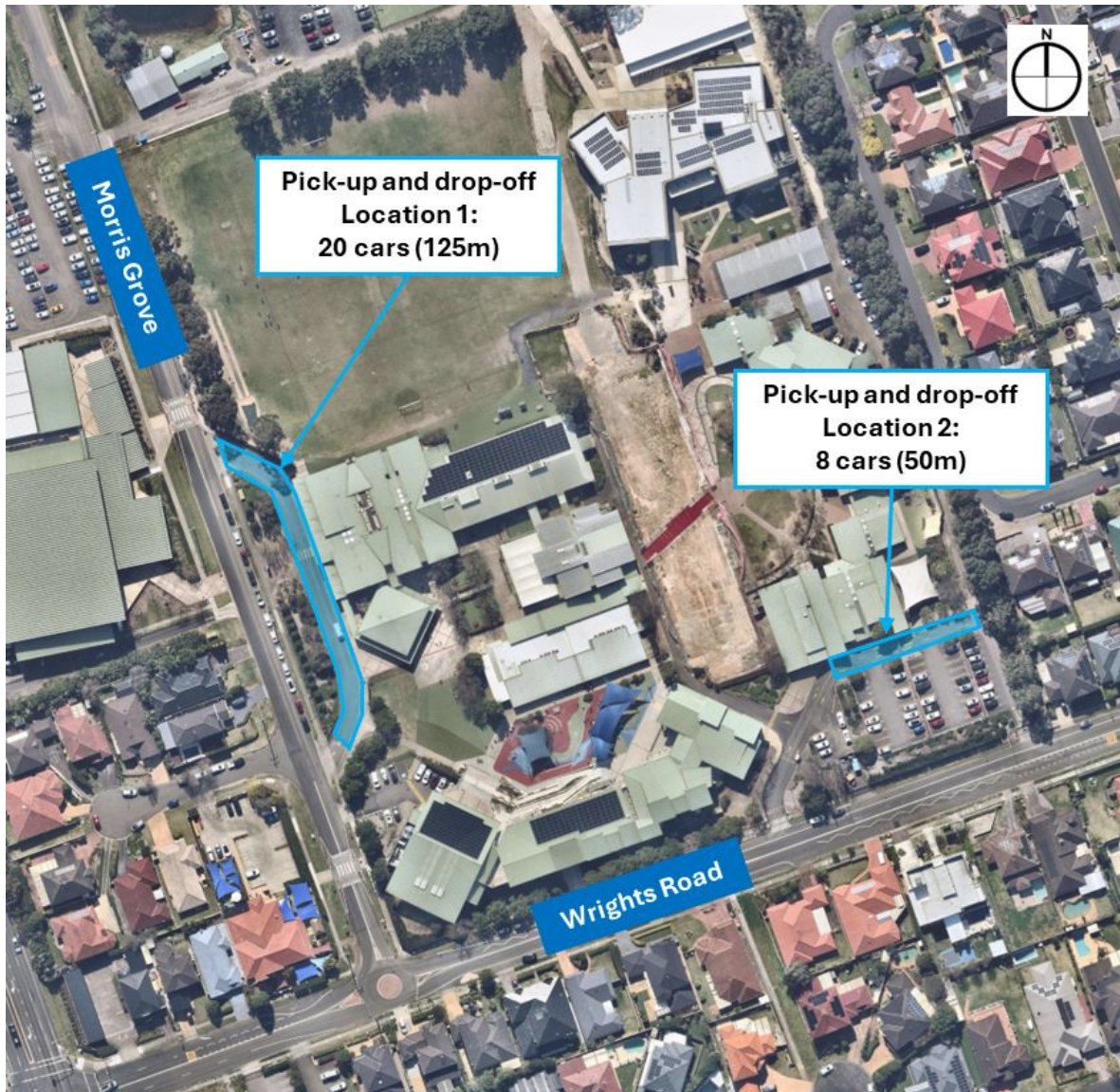

Figure 2.4 Existing school pick-up and drop-off spaces

2.4 Road network

The subject site is located in the suburb of Kellyville Hill, bordered by Green Road to the west, Wrights Road to the south, Cormack Circuit to the east, with Morris Grove running north-south through the site.

Green Road is a regional road running north-south with a divided carriageway, generally offering two lanes in each direction and additional turn lanes at the intersection with Wrights Road. The carriageway width ranges from 17m to 19m, with a speed limit of 60 km/h and no on-street parking allowed. It also features a signalised intersection with Wrights Road to the west of the site.

Wrights Road is an east-west collector road with an undivided carriageway, usually consisting of one lane in each direction, expanding to two lanes near the site. The carriageway width varies between 12.5m and 14m, with a speed limit of 50 km/h and a school zone present. There are four access points to the subject site. Parking regulations include a "Loading Zone," "Bus Zone," and unrestricted parking.

Morris Grove is a council-owned local road running north-south with an undivided carriageway and one lane in each direction. It is a no-through road with a speed limit of 50 km/h, providing access to the subject site, William Clarke College Sports Centre, and the Secondary School staff car park. Parking controls include "No Parking" during school hours, unrestricted parallel parking on the western side, and some informal unrestricted 90-degree parking on the eastern side near the staff car park.

Cormack Circuit is a local road aligned north-south adjacent to the site, but it does not provide access to the site. It features an undivided carriageway with one lane in each direction and a speed limit of 50 km/h.

2.4.1 Intersection performance

To confirm the existing and future operation of the intersections near the subject site, a traffic assessment was conducted using SIDRA modelling software by PTC as part of the traffic impact assessment for the proposed development. Table 2.1 summarises the relevant SIDRA results.

Table 2.1 SIDRA modelling output

Intersection	Scenarios	Peak	Level of Service	Average Delay (Sec)	Degree of Saturation	highest 95 th % queue (m)
Green Road / President Road / Rosebery Road	Existing Base	AM	B	17.4	0.960	147.8
		PM	A	12.2	0.907	92.9
	2026 Base	AM	C	38.2	1.083	389.7
		PM	B	24.4	10.65	279.4
	2026 Development	AM	C	38.2	1.083	389.7
		PM	B	24.4	1.065	279.4
Green Road / Wrights Road	Existing Base	AM	F	88.2	1.072	366.1
		PM	C	39.5	0.782	176.9
	2026 Base	AM	F	103.4	1.115	423.7
		PM	D	42.5	0.862	218.4

Intersection	Scenarios	Peak	Level of Service	Average Delay (Sec)	Degree of Satruation	highest 95 th % queue (m)
	2026 Development	AM	F	103.4	1.115	423.7
		PM	D	42.5	0.862	218.4
Wrights Road / Morris Grove	Existing Base	AM	A	4.3	0.553	69.1
		PM	A	3.8	0.185	8.1
	2026 Base	AM	A	4.3	0.549	89.7
		PM	A	3.8	0.184	8.1
	2026 Development	AM	A	4.3	0.553	90.8
		PM	A	3.8	0.184	8.1

Source: William Clarke College Traffic impact assessment, Revision 4 (27 June 2023, ptc)

Green Road / President Road / Roseberry Road – the existing average Level of Service (LoS) is B in the AM and A in the PM, with the worst turn movements experiencing a LoS C during both peak periods. In the 2026 Base Case scenario, the roundabout maintains an average LoS of C in the morning and B in the afternoon, indicating satisfactory operational levels. No operational changes are expected in the 2026 Development scenario.

Green Road / Wrights Road – the existing overall LoS is F during the AM peak and C during the PM peak. The intersection currently operates with a maximum Degree of Saturation (DoS) exceeding 1.07, indicating no spare capacity in the AM peak and more than 20% available capacity in the PM peak. This performance is considered poor due to high background traffic in the north-south direction.

In the 2026 Base Case scenario, additional background traffic growth worsens all performance indicators, pushing the LoS beyond capacity in both the morning and afternoon. However, this condition is already present. No operational changes are anticipated in the 2026 Development scenario. It should also be noted that the construction peak would not align with the background traffic peak period.

Wrights Road / Morris Grove – the current operation is satisfactory, with a LoS A during both the AM and PM peak hours. In both the 2026 Base and 2026 Development scenarios, the intersection performance indicators are expected to remain unchanged, as the area is largely developed and unlikely to experience significant background traffic growth.

2.5 Public transport

Figure 2.5 shows the locations of the nearest bus stops within a 400m catchment area of the subject site.

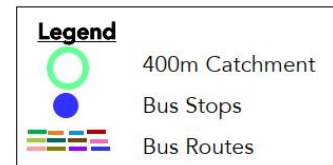

Source: William Clarke College Traffic Impact Assessment (PTC, June 2023)

Figure 2.5 Existing bus stops near the Subject site

Public transport services including public and private / school buses stopping within 400m-800m from the Subject site are shown in Figure 2.8. The extent of bus services providing direct connectivity to the school is presented in Figure 2.7.

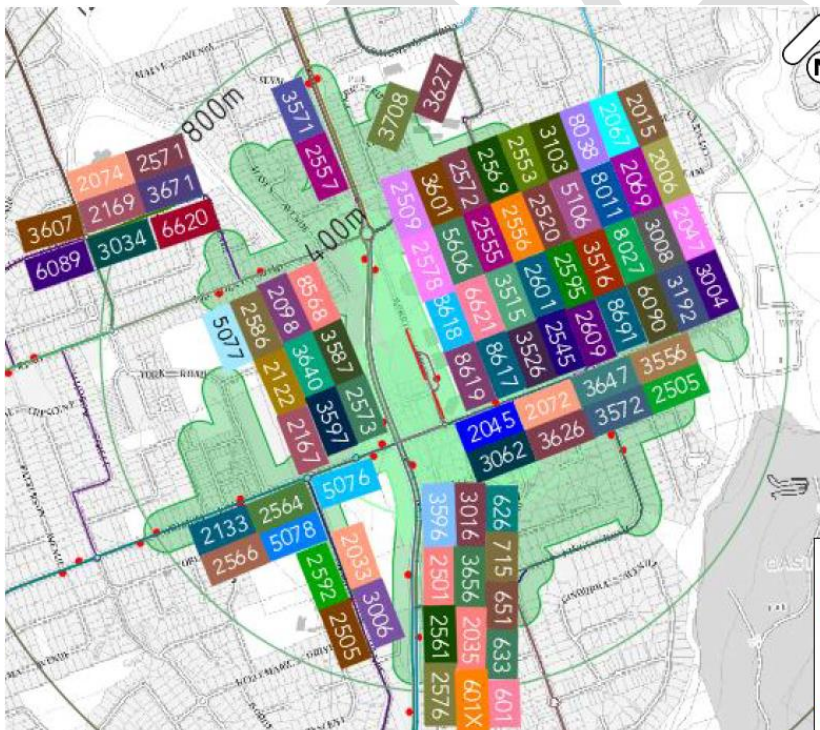

Source: William Clarke College Traffic Impact Assessment (PTC, June 2023)

Figure 2.6 Private and school buses service

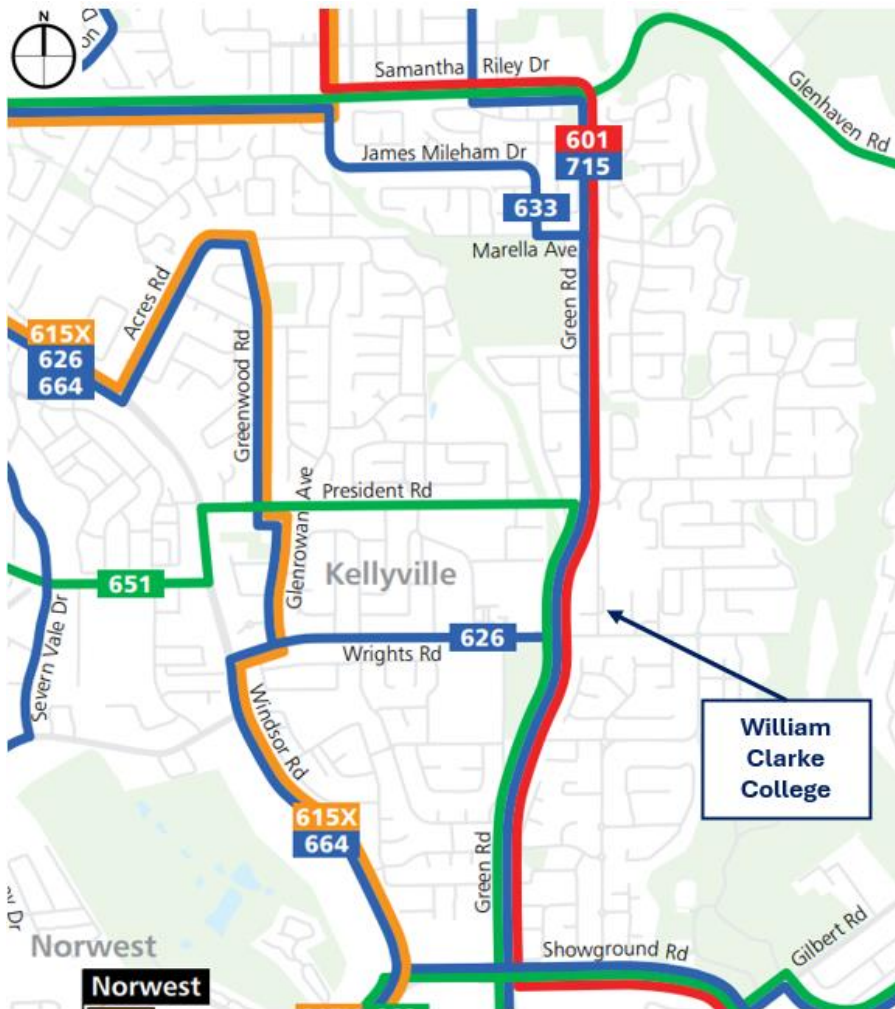

Source: CDC NSW Bus network map (https://cdcbus.com.au/wp-content/uploads/2021/12/Region_4_Network_Map.pdf)

Figure 2.7 Existing public bus service

Overall, the school is well-served within its informal enrolment area, with the majority of students having direct bus connections to and from the school.

2.6 Pedestrians and cyclists

Active transport infrastructure is defined as allocated off-road or on-road facilities for pedestrians and cyclists to travel. These can be provided in a mixed traffic condition, visually separated, physically separated or segregated from the main traffic lanes or public transport corridor.

Adjacent to the subject site, Wrights Road and Morris Grove are equipped with paved pedestrian footpaths on both sides. These paths include mid-block pedestrian crossings on Wrights Road and Morris Grove, as well as signalised pedestrian crossings at the intersection of Green Road and Wrights Road, facilitating pedestrian movement in the local area.

According to the Cycleway Finder from Transport for NSW, there are shared-use paths surrounding the subject site, as shown in Figure 2.8. Designated shared paths are provided to the north and northwest of the school, where a significant proportion of students reside.

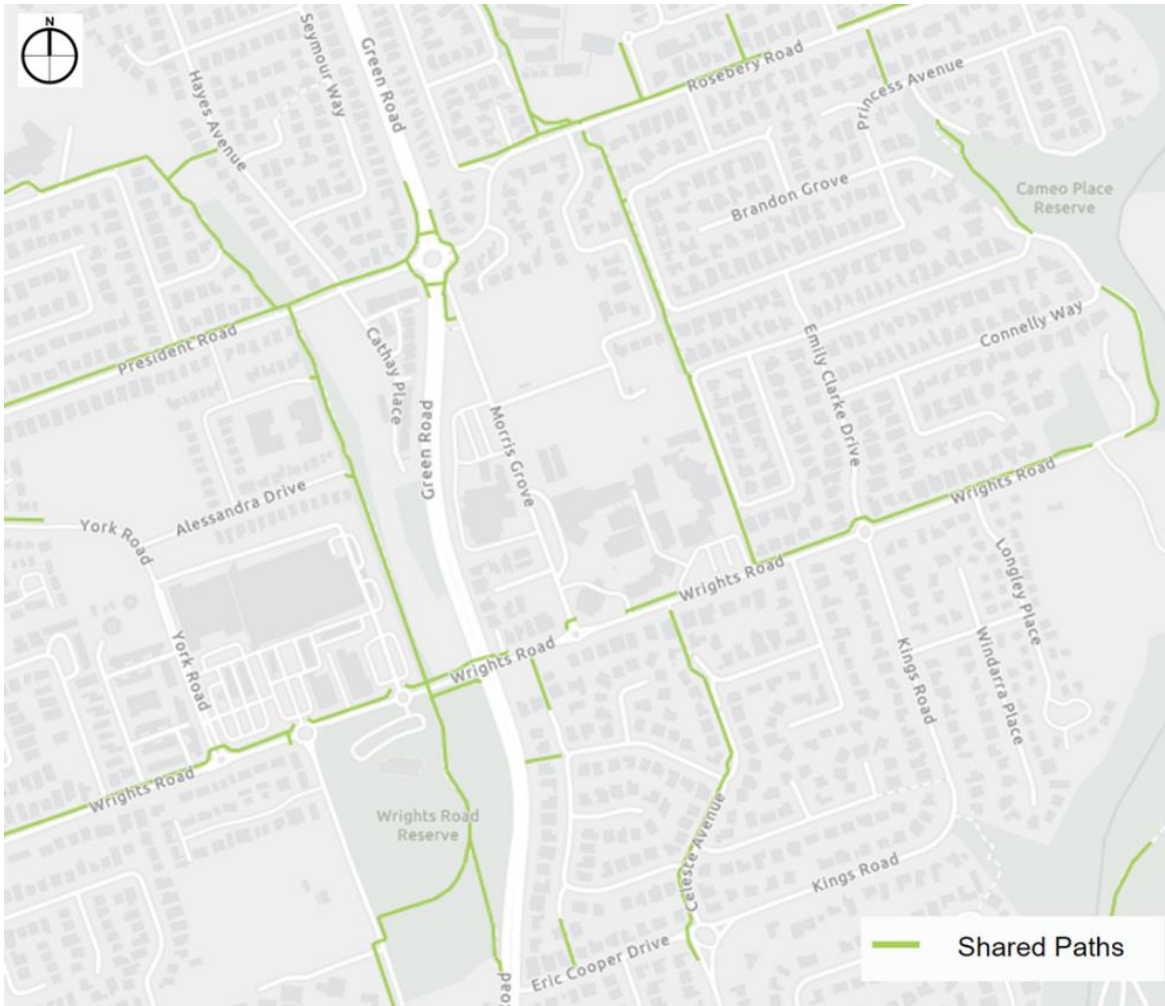

Source: *Cycleway Finder (Transport for NSW)*
Figure 2.8 Existing shared paths

2.7 Parking

The subject site currently accommodates a total of 238 parking spaces as shown in Figure 2.9.



Figure 2.9 Existing parking provision

3 Proposed Stage 1 project

3.1 Description of construction activities

As part of Stage 1 of the project, the following construction activities are to be undertaken by Rohrig Constructions. It is anticipated that the Contract will commence works with the site stripping & surveying. Once completed, the construction of the structure will commence. **Please note that the carpark and waste compound works are not part of this plan.**

Site Establishment

All construction activities will be undertaken within the site.

The main construction vehicles access to the site will be provided via the existing maintenance vehicle gate (Gate 14) on Morris Grove. Upon entering the site, vehicles will drive all the way to the northeast corner and drive south towards the proposed material laydown area.

At times where the mobile crane near the primary school is required, access off Wrights Road will be needed. This will occur while maintaining the car park and outside school peak hours with the help of fencing and controllers to ensure enclosure of the area required for the vehicles to turn around.

Car parking for construction workers will be provided within the site and the access to it will be provided via Gate 14. Temporary pedestrian bridges will be provided over the construction vehicle driveways to enable access to the ovals.

The route and markups are presented in Figure 3.1 below.

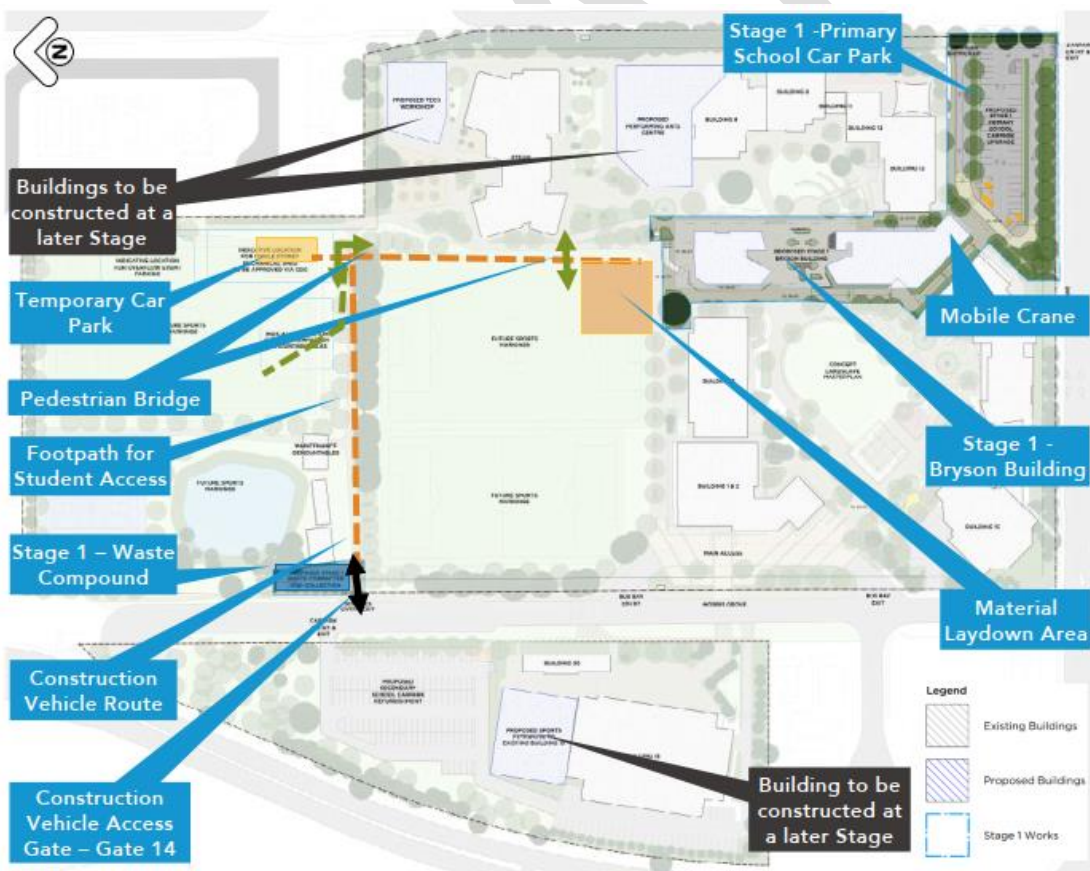

Source: William Clarke College Traffic Impact Assessment (PTC, June 2023)

Figure 3.1 Construction activities Stage 1 (note carpark and waste compound not included in this scope or plan)

Staging of Works

Construction was initially proposed as commencing upon completion of 2024 HSC exams, with the reasoning being that senior student that drive to the School would no longer attend on a daily basis and carparking in the student carpark off Morris Grove becomes available for redirected teacher parking in conjunction with existing spare capacity in the carpark beneath and surrounding the Sports Centre.

With the carpark and waste compound works not included in this scope, the commencement of Stage 1 works (the Bryson Building) has been adjusted to commence in mid-September 2024 as access to carparking areas is not required for this work.

Bryson Building Construction

Timeframe - 14-16 months

All demolition and construction works to be undertaken with access via the site compound and internal access via the centre of the site.

Student and staff access between the east and west parts of the site to be via temporary pedestrian bridges over the internal construction site driveway.

The main phase of works (stage 3) has been broken into the following phases of construction:

Preliminary Works

To commence works, Rohrig will take possession of the site. Site hoardings & pedestrian gantries will be installed to all interfaces to the school. The site access road off Morris Grove will have site fencing erected on either side, with a site entry gate off Morris Grove, and an additional gate adjacent to the site. The access road off Morris Grove will be single lane, so traffic management along this road will be paramount to successfully delivering the project. A temporary car park will be established adjacent to the site. Once the site has been safely established and the required facilities and environmental controls are in place site stripping will be undertaken. The completion of these works will allow for the construction of the main works to kick off.

Groundworks and substructure

Once the building platform has been properly prepared, construction of the main building structure will kick off. Detail excavation of pits & footings will commence. Rohrig plan to work in a North to South direction, progressively excavating and pouring footings & pits in that general direction. Once the construction of enough footings on the Northern side has occurred, Rohrig will commence the inground & subgrade works, and pour the slab. Whilst the Northern slab works are underway, construction of footings to the Southern side will commence. The staging of these works allows for a flow of resources, to ensure that no single trade is overly burdened throughout the construction of the slab on ground.

Structure

Similar to the footings & slabs on ground, the suspended slabs and steel structure have been broken into North & South areas. As mentioned, it allows for reasonable trade resource allocation, and is the also the most efficient & economical way for the building to be constructed. Once the concrete structure has been completed, erection of structural steel will follow. Once the concrete slabs have cured sufficiently, the slabs will be stripped to allow for the succeeding trades to commence works within the different work areas.

Cladding & Roofing

Roofing works will commence once the structural steel roof has been erected, whilst cladding works progressively commence on each level, as the slab above is stripped and back propped, and the area becomes available. Once the cladding works are completed and the building is deemed to be mainly watertight, façade finishes will occur, and the scaffold will then be stripped from the perimeter of the building. Once the scaffolding has been removed, external works adjacent to the main building will commence.

Internal Services & Finishes / Commissioning & Handover

Like the commencement of the external cladding, the commencement of internal services & finishes occurs progressively, as areas are stripped and become accessible for fit out trades. A typical fit out methodology commences with installation of High-Level services. Once they have progressed sufficiently, construction of the internal walls, ceiling framing and sheeting occurs. Individual areas will then commence their specific fit out, including specific fit outs such as the roof terrace, amenities areas and Void / Planter construction, etc.

Once the fit out of individual areas has progressed, remaining finishes occur, including the installation of joinery, fit-off of services, installation of feature panelling, hardware, signage, inboards, carpet, FF&E and defects.

Once the entire building has rectified preliminary defects, Rohrig will undertake a final defect inspection & rectification, and testing & commissioning of the entire building. On completion of the commissioning, Rohrig will achieve practical completion.

3.2 Timing and hours of works

General

The proposed hours of work subject to consent are:

- Monday to Friday: 7:00am – 5:00pm
- Saturdays: 7:00am – 1:00pm
- Sunday & Public Holidays – No Work unless upon application.

School Schedule and Significant Events

The works will need to be co-ordinated around the School Timetable and Significant events that are hosted by the school. School bell times will remain unchanged.

In order to minimise the possibility of conflict with parents and students during school drop-off and pickup times, construction vehicle access will be restricted at the following times.

- 7:45am – 8:45am Monday – Friday
- 2:45pm – 3:45pm Monday – Friday

Construction activities may also be restricted during significant events held on the eastern portion of the site. The College will liaise with the lead contractor in this regard.

3.3 Construction methodology

The following key tasks are proposed and their connection and interface to pedestrian and traffic management included.

3.3.1 *Site access, site establishment, fencing & hoardings*

Hoardings will be erected prior to the commencement of the project. All hoardings will meet council requirements, i.e., Signage can be erected to hoardings.

Project Duration site security will be established by the way of gates:

- Entry Gate – Morris Grove (access to both the site & site car park).

3.3.2 *Site compound*

During the construction works, Rohrig will establish a site compound within the Eastern corner area of the current playing ovals. Rohrig will establish within designated area, site amenities in compliance with the Safe Work Australia

code of practice. This will consist of a project office, lunchrooms, change rooms, ablutions, a first aid and induction /security shed.

Access to the compound will be via a fenced single lane roadway across the oval coming off the currently used maintenance access road. Staff and students will be able to cross this access road by the way of a gantry crossing.

Refer to Appendix F of the CEMP for site layout and general arrangement.

3.3.3 Works zone

Rohrig have inspected the site and believe that there is sufficient room for vehicles to enter, turn around and exit unimpeded. The area immediately within the site will act as a delivery drop off zone & work zone, where concrete pumps and trucks will operate.

3.3.4 Deliveries and material handling

The methods of material handling procedures during construction works are outlined as on the materials handling plan provided and are as follows:

All deliveries to the site will be coordinated by Rohrig's materials handling manager and will be directed via qualified traffic controllers to enter the site via the appropriate gate located at the end of Morris Grove Road.. Any deliveries not co-ordinated will be turned away from site.

Delivered materials will be stored in the site area only. The main material handling equipment on site will be a concrete pump, scissors, boom lifts and forklifts, which will also be stored in the builder's compound at all times as well as a site dumper for internal movement of material on site.

All deliveries will be directed to relevant Construction zone and will be offloaded using forklifts, hi-abs and the crane. This includes large deliveries such as reinforcement and structural steel.

Deliveries will occur within approved construction hours and unloading of deliveries will occur within the site in most cases.

It will be key to ensure that all deliveries are booked in, and material handling methods are efficient.

3.3.5 Concrete pumping

A mobile concrete pump station will be installed during duration of the construction of the structure.

A mobile concrete pump will be located in the work zone and pump concrete on pour days.

All concrete delivered and placement activities will occur within the approved hours of construction.

3.3.6 Cranage

Large deliveries such as reinforcement, formwork will be off loaded on site via the tower cranes. Deliveries will occur within approved construction hours and unloading of deliveries will occur within the site in most cases.

3.3.7 Rubbish removal

During construction it is proposed that waste be placed in bins and taken to the ground level using rubbish chutes, or craned skip bins down to the Ground level for collection within the site.

3.4 Construction traffic

3.4.1 Construction vehicle volumes and types

The construction is likely to generate a maximum of up to 30 truck movements per day (15 in and 15 outbound) at its peak during concrete pours.

Throughout various stages of the project, the average number of construction vehicles per day is anticipated to be as follows:

- Enabling works: 20 truck movements per day (10 in and 10 outbound)
- General construction: 30 truck movements per day (15 in and 15 outbound)
- Fit out: 30 truck movements per day (15 in and 15 outbound)
- Landscaping works: 20 truck movements per day (10 in and 10 outbound).

With construction work hours between 7:00am and 5:00pm and no construction vehicle access during the morning and afternoon school peak hours, there would be an 8-hour window for construction trucks to enter / exit the site. The anticipated maximum construction traffic generation of 30 truck movements (15 in and 15 outbound) during those 8 hours results in 3.75 movements per hour, which is less than 1 movement per 15 minutes. This is considered negligible from a traffic perspective and lies within the levels of daily traffic fluctuation.

The contractor is likely to require on average 30-40 and maximum 60 staff per day. With some level of car-pooling and utilisation of public transport, it is expected that on average 30, and maximum 50 light vehicles will arrive to the site. Construction staff are anticipated to arrive / depart outside the main school peak hours, i.e. before 7am and after 5pm, thus the traffic impact on the surrounding roads is anticipated to be minor.

3.4.2 Construction vehicle routes and site access

The site is located within the Hills Shire Council LGA and the proposed construction vehicle routes have regard for the surrounding traffic arrangements in the vicinity of the site. No queuing or marshalling of trucks is permitted on any public road and all loading and unloading of materials will be undertaken within the site.

All vehicle routes to site are constrained to existing public roads that have the physical geometry to accommodate the turning movements.

In term of the broader road network, the site is accessible from the east via the M2 Motorway, west via the M7 Motorway and north and south via Old Windsor Road. Vehicles travelling from all directions shall arrive at Northwest Boulevard, turn left into Windsor Road, turn right into Showground Road, turn left into Green Road and then turn right into Wrights Road.

Upon exiting the site, all vehicles shall exit the site via Wrights Road, turn left into Green Road, turn right into Showground Road, turn left into Windsor Road, turn right into Northwest Boulevard. Upon approaching the Old Windsor Road, the vehicles travelling towards west shall continue straight on Northwest Boulevard towards M7 motorway, the vehicles travelling towards north shall turn right on Old Windsor Road and the vehicles travelling towards the north and east shall turn left on the Old Windsor Road.

Please refer to Figure 3.2. The approved truck route plan shall form part of the contract and must be distributed to all truck drivers.

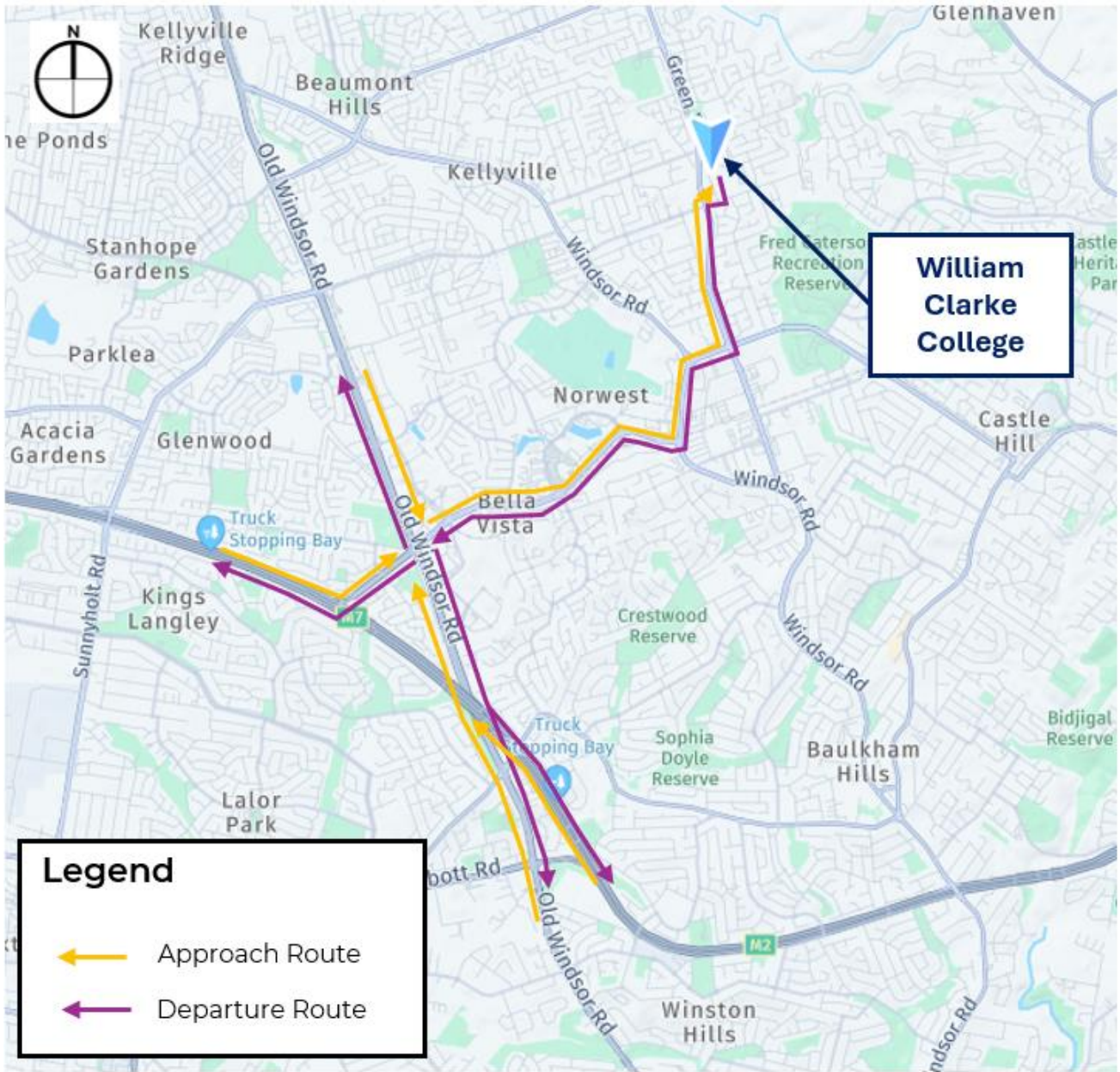

Figure 3.2 Construction traffic access routes

3.4.3 Construction plant and equipment

All construction vehicles will be contained wholly within the work site and defined parking areas adjacent to the Bryson Building works area. All construction related vehicles must enter and exit the site via the defined site access point and not impede traffic on surrounding streets.

There must be sufficient parking facilities on-site, including for heavy vehicles and for site personnel, to ensure that construction traffic associated with the development does not utilise public and residential streets or public parking facilities.

3.4.4 *Driver code of conduct*

Prior to the commencement of construction, a Driver Code of Conduct is to be prepared and communicated to heavy vehicle drivers as part of induction. This must be adhered to in order to minimise impacts of construction on the local and regional road network by managing access routes and driver behaviour.

3.5 Construction traffic management

The following actions would be implemented manage construction traffic, minimising the impact of construction traffic and reducing any safety concerns.

The main objective of the construction traffic management plan is to establish guidelines and standards to address traffic issues arising from construction activities. Construction traffic and parking at the subject site are constrained by site conditions and public traffic movements. The key issues affecting this project include:

- General site access and egress
- Location and availability of parking
- Timing and extent of material deliveries
- Conflicts between existing vehicles and construction traffic
- Traffic congestion and conflicts on external roads
- Signage and directional information.

To manage construction traffic, the following actions will be implemented to minimise its impact and address safety concerns:

- Vehicle deliveries will be managed by traffic controllers where necessary to ensure public safety and minimise the impact on local traffic flow.
- Safe access and clear visibility for pedestrians and vehicles will be maintained at all times when traffic enters and exits the site.
- Rohrig will oversee traffic management around the site, including on surrounding streets as required.

3.5.1 *Construction vehicles*

The main access point for construction vehicles entering and exiting the site will be via Gate 14 on Morris Grove, with all other access points restricted for construction vehicle use.

All construction traffic and material storage will be confined within the site. Access to construction areas, including the Bryson building site, material laydown area, and the temporary car park for construction vehicles, will be restricted to approved contractors and staff wearing appropriate PPE. Public access to these sites will be prohibited unless approved by the site manager, with clearly marked signage stating, 'For Construction Access Only'.

3.5.2 *Cyclists and pedestrians*

The existing pedestrian and cyclist access to the Subject site will be maintained at the following locations during the construction period, as they are clear of any proposed construction works:

- Gates 9 to 12, located along Morris Grove
- Gate 4 on Wrights Road
- Gate 1 for Prep access off Cormack Circuit
- Note there will be no pedestrian access past gate 14

3.5.3 *Public transport*

The existing school bus drop-off and pick-up zone accessed via Morris Grove, as well as the bus stops on Wrights Road, will remain unchanged during the construction period.

DRAFT

4 Impacts of the proposed works

4.1 Impacts to traffic

The estimated construction traffic impact, including up to 30 heavy vehicle movements per day (15 in and 15 outbound), equating to approximately 1 truck movement every 15 minutes, is considered minimal and can be easily accommodated by the surrounding road network. While slow truck manoeuvring at Gate 14 on Morris Grove may temporarily affect traffic flow, it is expected to have minimal impact due to the low traffic volume on this no-through road. Additionally, construction vehicle movements will be restricted during school drop-off and pick-up times to minimise potential conflicts with parents and students. Traffic controllers will assist with vehicle access to and from the project site, further mitigating any associated impacts.

During peak construction periods, up to 50 light vehicles from construction staff are expected, but these are expected to arrive and depart outside of school peak hours (before 7 am and after 5 pm), minimising any effect on peak traffic flows.

As detailed in Section **Error! Reference source not found.**, the Wrights Road and Morris Grove intersection is currently operating at a satisfactory level during both AM and PM peak hours. Although the Green Road and Wrights Road intersection operates at an unsatisfactory level (LoS F) during the AM peak hour due to heavy background traffic, the low volume of construction-related traffic during peak hours is unlikely to significantly impact traffic flows. Therefore, the overall traffic impact of the construction activities on the surrounding road network is expected to be negligible.

4.2 Impacts to pedestrians and cyclists

The anticipated construction traffic is not expected to significantly impact pedestrians and cyclists using Morris Grove. Traffic controllers stationed at Gate 14 will manage potential conflicts between pedestrians, cyclists, general traffic, and construction vehicles to minimise the risk of collisions near the site access.

Existing pedestrian and cyclist access to the College will be maintained throughout the construction period. Construction traffic will have limited interaction with active travel users, as vehicle movements will be restricted during school drop-off and pick-up times, further reducing any potential risks to pedestrians and cyclists.

Student and staff access between the east and west parts of the site to be via temporary pedestrian bridges over the internal construction site driveway.

4.3 Impacts to public transport

During construction activities, traffic related to the project is unlikely to cause any adverse impacts on the school bus services currently operating on Morris Grove and Wrights Road. The additional traffic generated over the construction period is not expected to significantly affect the public transport network adjacent to the project site.

4.4 Impacts to parking

During the peak construction period, the number of contractors is expected to average between 30 to 40, potentially reaching up to 60 staff per day. With some car-pooling and public transport use, it is expected that an average of 30, and a maximum of 50 light vehicles will arrive at the site daily. All project light vehicles will be required to access the site via Gate 14 and park in the temporary car park within the site. Although the exact number of parking spaces in the temporary car park is not yet confirmed, Rohrig must ensure that adequate parking is provided on-site. Parking by construction contractors will be restricted to the site to avoid any loss of on-street parking spaces on the adjacent residential streets around the subject site.

4.5 Impacts to emergency vehicle access

No changes to access for emergency vehicles is proposed or required. There would be no disruption to emergency vehicles on Wrights Road and Morris Grove during the construction period.

DRAFT

5 Mitigation measures

5.1 Road safety

5.1.1 Pedestrian management

Pedestrian access to and around the site is to be maintained at all times.

The entire site (and any remote work areas when applicable) and during all phases will be physically separated from the School via A-Class fencing. The extents of fencing will be modified during the works as required to suit the works occurring at each project phase. The access points to the site will be securely locked even when the construction / demolition activities are not occurring.

It is noted that construction vehicle movements will be limited to hours outside of school peak times, meaning that construction vehicles will not interfere with school pick-up and drop-off activities.

Where relevant, it is proposed that gate controllers overlook vehicular and pedestrian movements when the construction vehicles enter or exit the site. The controllers will temporarily deploy a pedestrian barrier to stop pedestrians and then open the barrier when it is safe to continue on.

A 4m wide Pedestrian overpass will be provided over the construction access route within the site to enable conflict-free connectivity between the school and the ovals.

5.1.2 Signage

Traffic Signage will be utilized wherever traffic conditions may depart from the current conditions. This is expected to only affect Morris Grove towards Gate 14 adjacent to the new Waste Compound. Traffic Barriers & Delineation will be utilized inside the school grounds to separate the delivery and unloading areas from pedestrians.

TfNSW Accredited Traffic Controllers will be utilized to control deliveries at the unloading zones. Traffic Controllers will also be utilized during major concrete pours at the campus gate at Morris Grove.

5.1.3 Parking

Construction staff car parking arrangements will be provided within the site with vehicle access via Morris Grove, i.e., shared access with the construction vehicles. Site personnel will be advised to carpool and utilise public transport.

5.2 Traffic control

An articulated vehicle (AV) turning left from Wrights Road into Morris Grove needs to occupy the opposite direction lane. Therefore, a traffic controller will be required at Morris Grove to manage the southbound traffic. Refer to Figure 5.1 overpage for information.

It is anticipated that traffic control will be required for the following operations during the project:

- Large concrete pours (with numerous trucks required)
- Floating in and out of large machinery
- Excavation traffic to be contained within the site
- Reducing delivery vehicles to semi rigid trucks

All deliveries to be limited to semi rigid trucks other than when large machines need to be floated in and out of site. Traffic controller to be provided along Morris rd for deliveries with articulated vehicles are required.



Source: William Clarke College Traffic Impact Assessment (PTC, June 2023)

Figure 5.1 Traffic control required on Morris Grove near Wrights Road intersection

An AV exiting the site via the site driveway needs occupy the opposite direction lane on Morris Grove. Therefore, a traffic controller would be required at Morris Grove to manage the northbound traffic.

A gate controller will be present at the site access gate to coordinate between the incoming and outgoing vehicles as well as to managing pedestrian movements on the footpath when the trucks are entering or exiting the site.

Refer to Figure 5.2 for further information.



Source: William Clarke College Traffic Impact Assessment (PTC, June 2023)

Figure 5.2 Traffic control required on Morris Grove near Gate 14

5.3 Traffic Guidance Schemes

Traffic Guidance Schemes (TGSs) must be developed for all areas of work that impact the road network and related areas, requiring traffic control for all road users. The TGSs will outline the signs and devices that will be installed to warn pedestrians, cyclists, and traffic around or through the project site. These TGSs should be developed in consultation with the Hills Shire Council and other stakeholders, as required, and based on the AS1742.3 Manual of uniform traffic control devices – Part 3: Traffic Control for Works on Roads and the TfNSW Traffic Control at Work Sites (2022).

Certified traffic controllers will be positioned at key access points and within the closure to regulate traffic movements to and from the project site and adjacent properties.

5.4 Stakeholder consultation

Stakeholder consultation is currently in progress with both TfNSW and The Hills Shire Council. Notification emails have been issued to contact persons at both these organisations for comment requesting if further input is required to CTPMP. At the time of issue, no feedback has been received however Rohrig will accommodate requirements from these agencies as they require.

From: Miller, Ryan
Sent: Thursday, 5 September 2024 11:09 AM
To: simon.turner2@transport.nsw.gov.au; development.sydney@transport.nsw.gov.au; rbuckham@thehills.nsw.gov.au
Cc: Chun, Chris; Longman, Stuart
Subject: William Clarke College - Stage 1 Bryson Building Only - Construction Traffic and Pedestrian Management Plan

Hi Simon and Robert,

WSP have been engaged to prepare a Construction Environmental Management Plan (CEMP) which part of includes a Construction Traffic Pedestrian Management Plan (CTPMP).

As part of the Department of Planning & Environment (now Department of Planning, Housing & Infrastructure) conditions of consent, it requests that the CTPMP is prepared in consultation with both Transport for NSW and The Hills Shire Council.

The requirements of the CTPMP are as below:

C16. The Construction Traffic and Pedestrian Management Sub-Plan (CTPMSP) must be prepared to achieve the objective of ensuring safety and efficiency of the road network and address, but not be limited to, the following:

- (a) be prepared by a suitably qualified and experienced person(s);
- (b) be consistent with the Section 9 - Construction Pedestrian and Traffic Management Plan Methodology (Stage 1) in the Traffic Impact Assessment prepared by Ptc dated 27 June 2023;
- (c) be prepared in consultation with Council and TfNSW;
- (d) detail the measures that are to be implemented to ensure road safety and network efficiency during construction in consideration of potential impacts on general traffic, cyclists and pedestrians and bus services; and
- (e) detail heavy vehicle routes, access and parking arrangements.

I have also reviewed previous agency advice from both TfNSW and The Hills Shire Council from the Response to Submissions (RTS) received to ensure anything required to be addressed is included.

Could you please advise if there are any items both TfNSW and Council would like to see included in the CTPMP noting the above requirements particularly (d) and (e).

The references relating to this development are as follows:

TfNSW Reference Syd 22/0087/03
DPE Reference SS-35715221
Council Reference unable to find one

We are looking to submit the CTMP shortly. Please provide some feedback at your earliest convenience.

If you have any questions, please let me know. Thanks.

Regards,

Ryan



Ryan Miller
Senior Principal Engineer, Planning and Mobility

T: +61 2 92725324

Ryan.Miller@wsp.com

WSP Australia Pty Limited
Level 27, 680 George Street
Sydney, 2000
Australia

wsp.com/au

WSP acknowledges that every project we work on takes place on First Peoples lands. We recognise Aboriginal and Torres Strait Islander Peoples as the first scientists and engineers and pay our respects to Elders past and present.

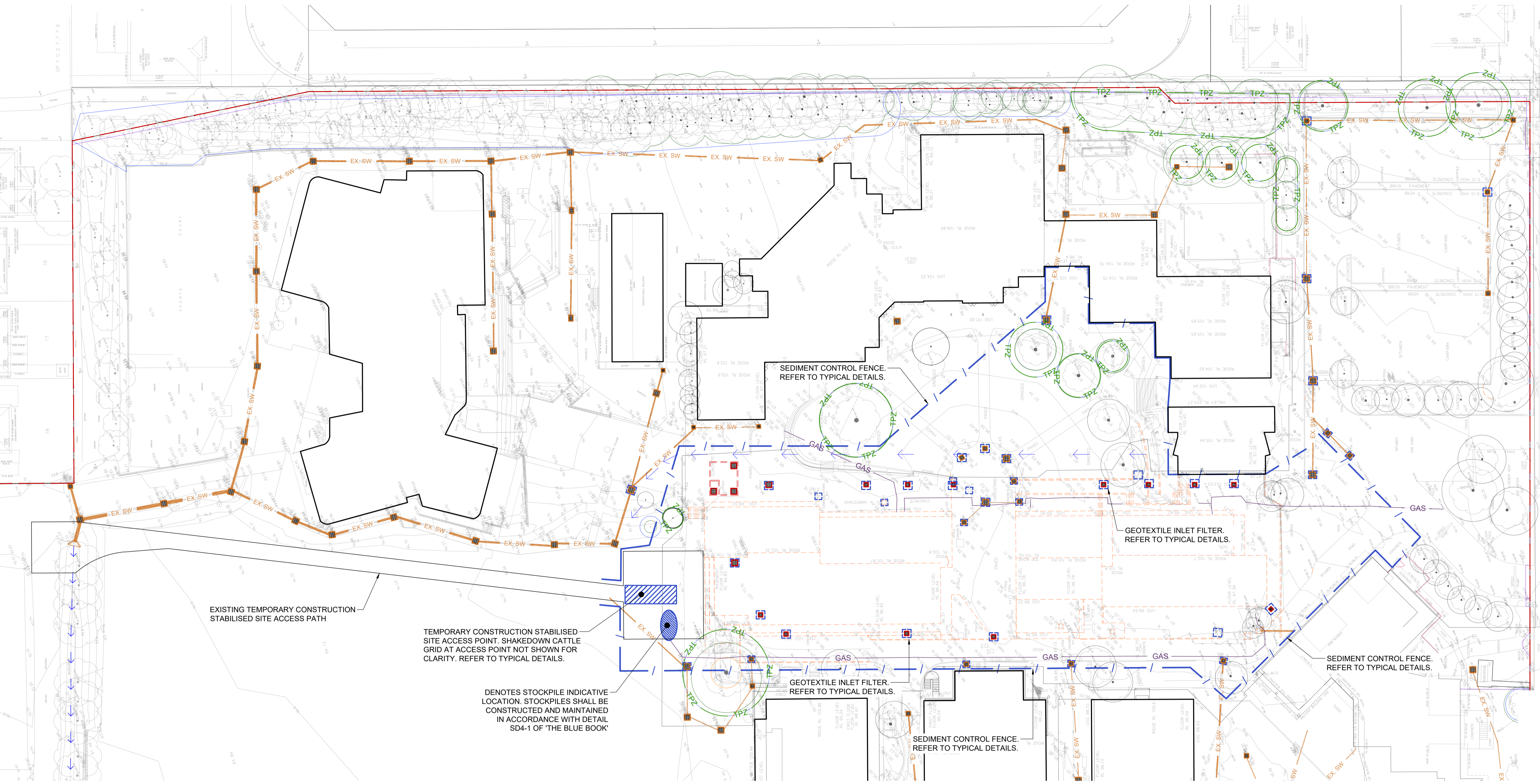

SOIL EROSION AND SEDIMENT CONTROL PLAN
SCALE 1:400

GENERAL NOTES:

- THIS PLAN IS A CONCEPT PLAN ONLY FOR CONSTRUCTION SEDIMENT & EROSION CONTROL. IT IS NOT SUITABLE FOR CONSTRUCTION. THIS PLAN SHOULD BE ADAPTED BY THE BUILDER DURING DEMOLITION, EXCAVATION & CONSTRUCTION PHASES TO ENSURE ADEQUATE PERFORMANCE.
- ALL DRAINAGE LAYOUT & DETAILS ARE DIAGRAMMATIC & INDICATIVE ONLY. ACTUAL LOCATION, SIZES, LEVELS & GRADES MAY LATER WHEN DETAIL DESIGN WORKS ARE DOCUMENTED.

EROSION & SEDIMENTATION CONTROL NOTES

- CONTRACTOR SHALL PROVIDE SEDIMENT FENCING MATERIAL DURING CONSTRUCTION TO THE LOW SIDE OF THE WORKS. TIE SEDIMENT FENCING MATERIAL TO CYCLONE WIRE SECURITY FENCE. SEDIMENT CONTROL FABRIC SHALL BE AN APPROVED MATERIAL (EG. HUMES PROPEX SILT STOP) STANDING 300mm ABOVE GROUND & EXTENDING 150mm BELOW GROUND.
- EXISTING DRAINS LOCATED WITHIN THE SITE SHALL ALSO BE ISOLATED BY SEDIMENT FENCING MATERIAL.
- NO PARKING OR STOCKPILING OF MATERIAL IS PERMITTED ON THE LOWER SIDE OF THE SEDIMENT FENCE.
- GRASS VERGES SHALL BE MAINTAINED AS MUCH AS PRACTICAL TO PROVIDE A BUFFER ZONE TO THE CONSTRUCTION SITE.
- CONSTRUCTION ENTRY/EXIT SHALL BE VIA THE LOCATION NOTED ON THE DRAWING. CONTRACTOR SHALL ENSURE ALL DROPPABLE SOIL & SEDIMENT IS REMOVED PRIOR TO CONSTRUCTION TRAFFIC EXITING SITE. CONTRACTOR SHALL ENSURE ALL CONSTRUCTION TRAFFIC ENTERING & LEAVING THE SITE DO SO IN A FORWARD DIRECTION. MAINTENANCE AND AUDITING OF SEDIMENT AND EROSION CONTROL IN ACCORDANCE WITH THE BLUE BOOK AND ANY RELEVANT CONSENT CONDITIONS.
- LOW POINTS OF EXCAVATION SHALL BE PUMPED TO THE SEDIMENT BASIN WHERE PROVIDED.
- PROVIDE WIND, AND DUST CONTROL IN ACCORDANCE WITH THE BLUE BOOK.
- PROVIDE BUNDS AND CATCH DRAINS AT THE TOP OF ALL BATTERS SO BATTERS ARE NOT ERODED WITH OVERLAND FLOW STORMWATER RUNOFF.

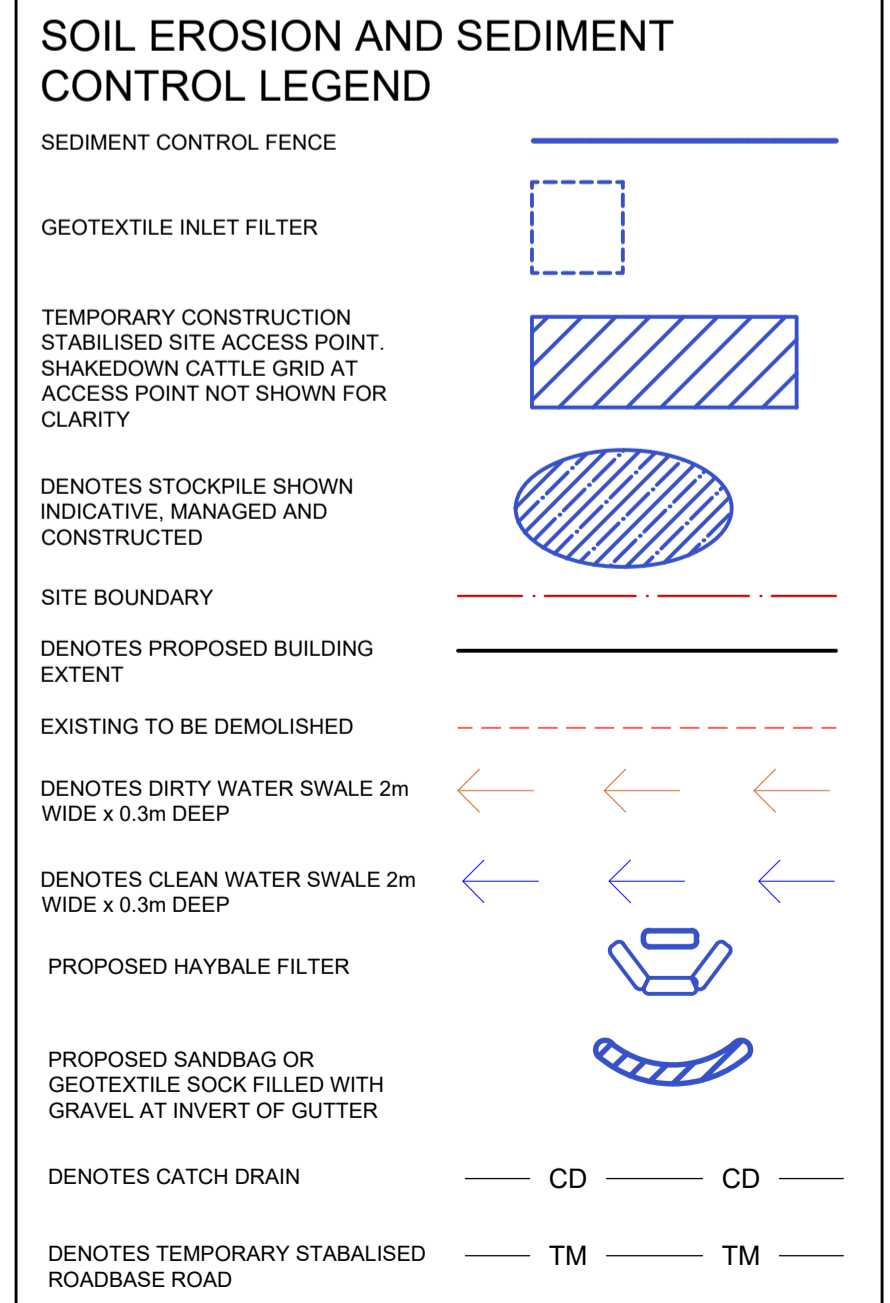

PRELIMINARY ISSUE
NOT FOR CONSTRUCTION

ISSUE	DESCRIPTION	APPROVED	DATE
A	ISSUE FOR TENDER		05.04.24

ARCHITECT
PMDL ARCHITECTURE INTERIORS MASTERPLANNING
PMDL ARCHITECTURE + DESIGN PTY LTD ABN 66 006 181 177
NSW NOMINATED ARCHITECTS: ANDREW PENDER 017 DAVID MORRIS 0865 VICKI VAN DIJK 0476

BIRZULIS ASSOCIATES
CONSULTING STRUCTURAL & CIVIL ENGINEERS
583 DARLING STREET ROZELLE NSW 2039
tel: (02) 9555 7230 email: office@birzulisassociates.com
www.birzulisassociates.com

PROJECT
WILLIAM CLARKE COLLEGE
10 MORRIS GROVE, KELLYVILLE
- BRYSON BUILDING

TITLE
SOIL EROSION AND SEDIMENT CONTROL PLAN

SCALES	as noted @ A1	DATE	JULY 2023
DRAWN	C.KE	DESIGN	GK/MG
VERIFIED		APPROVED	

This drawing is the copyright of Birzulis Associates P/L and may not be altered, reproduced or transmitted in any form or by any means in part or in whole without the written permission of Birzulis Associates P/L. All levels and dimensions are to be checked and verified on site prior to the commencement of any work, making of shop drawings or fabrication of components. Do not scale drawings. Use Figure Dimensions.

ISSUE	PROJECT No.	DRAWING No.
A	8932	C.10

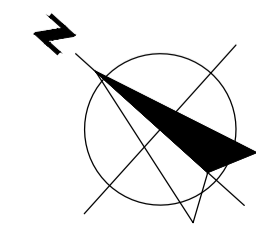

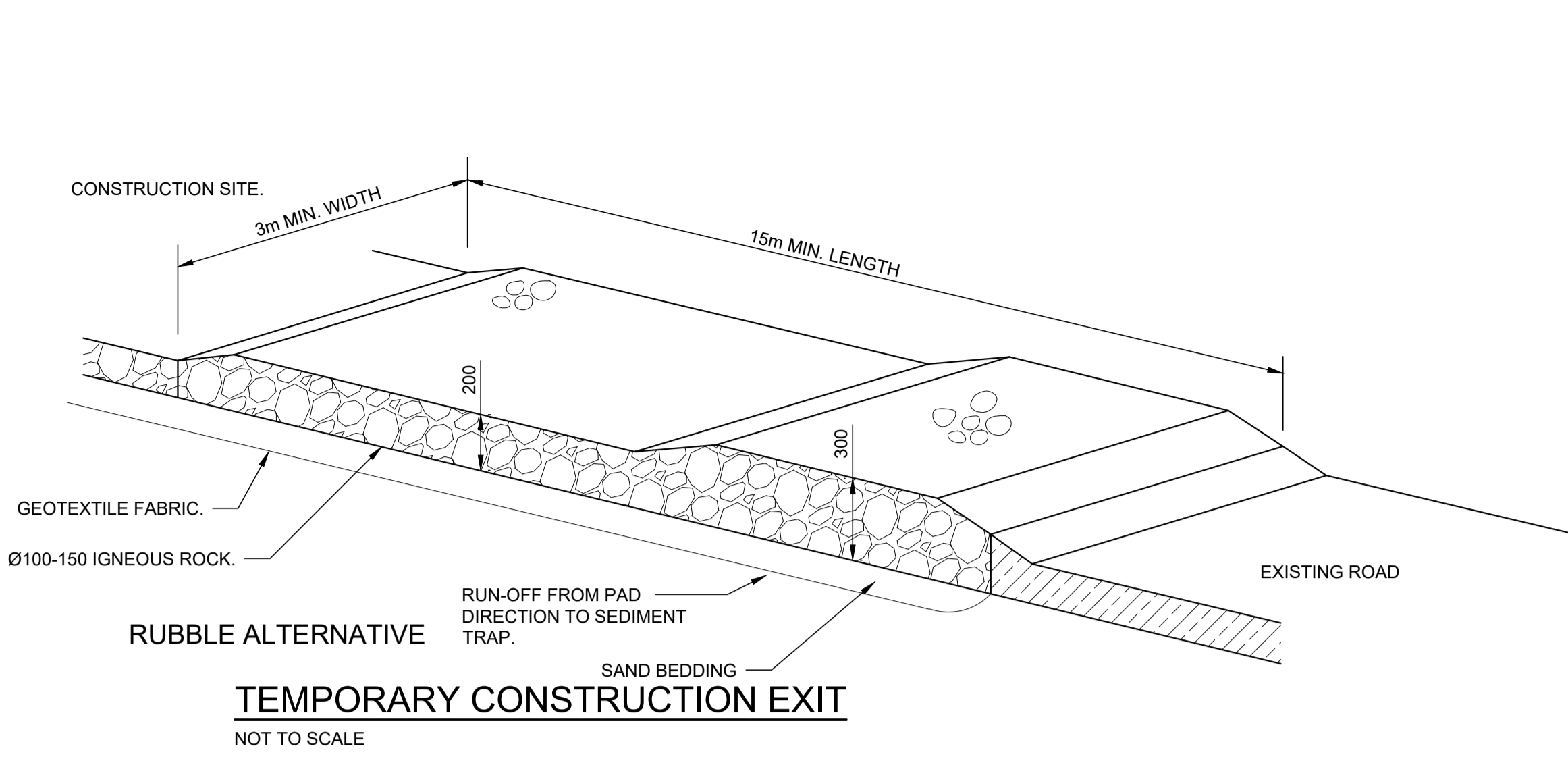

TEMPORARY CONSTRUCTION EXIT
NOT TO SCALE

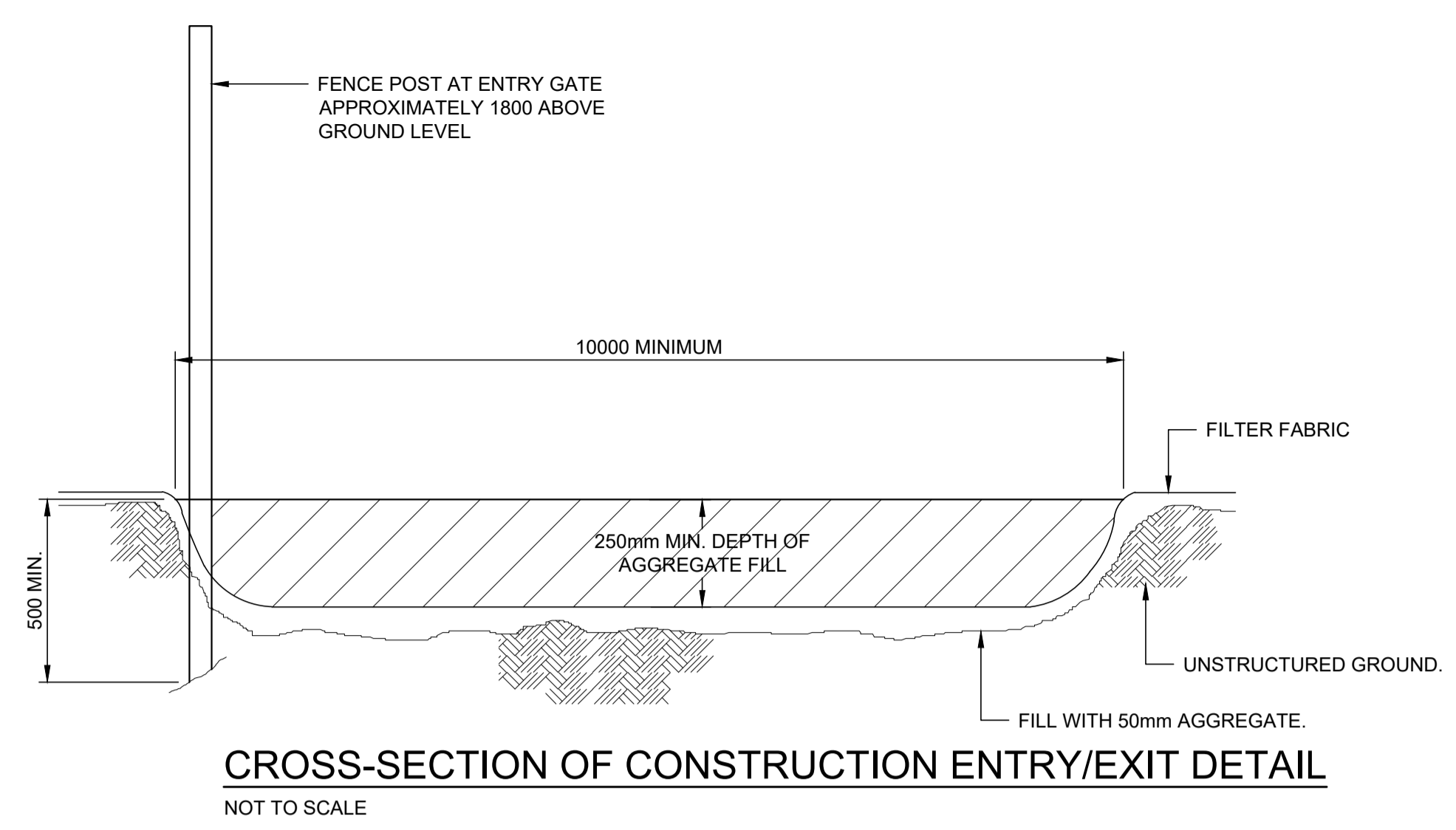

CROSS-SECTION OF CONSTRUCTION ENTRY/EXIT DETAIL
NOT TO SCALE

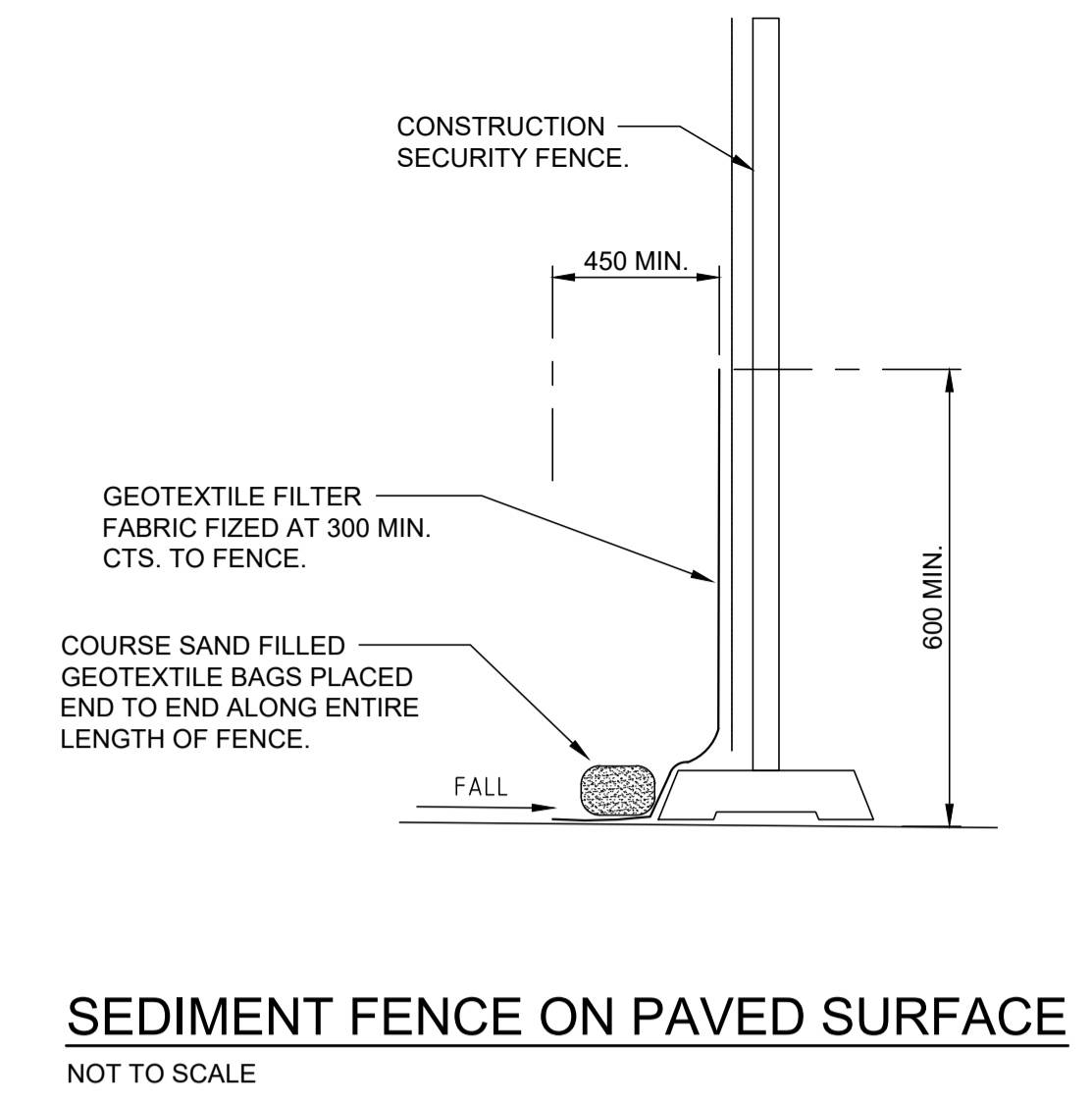

SEDIMENT FENCE ON PAVED SURFACE
NOT TO SCALE

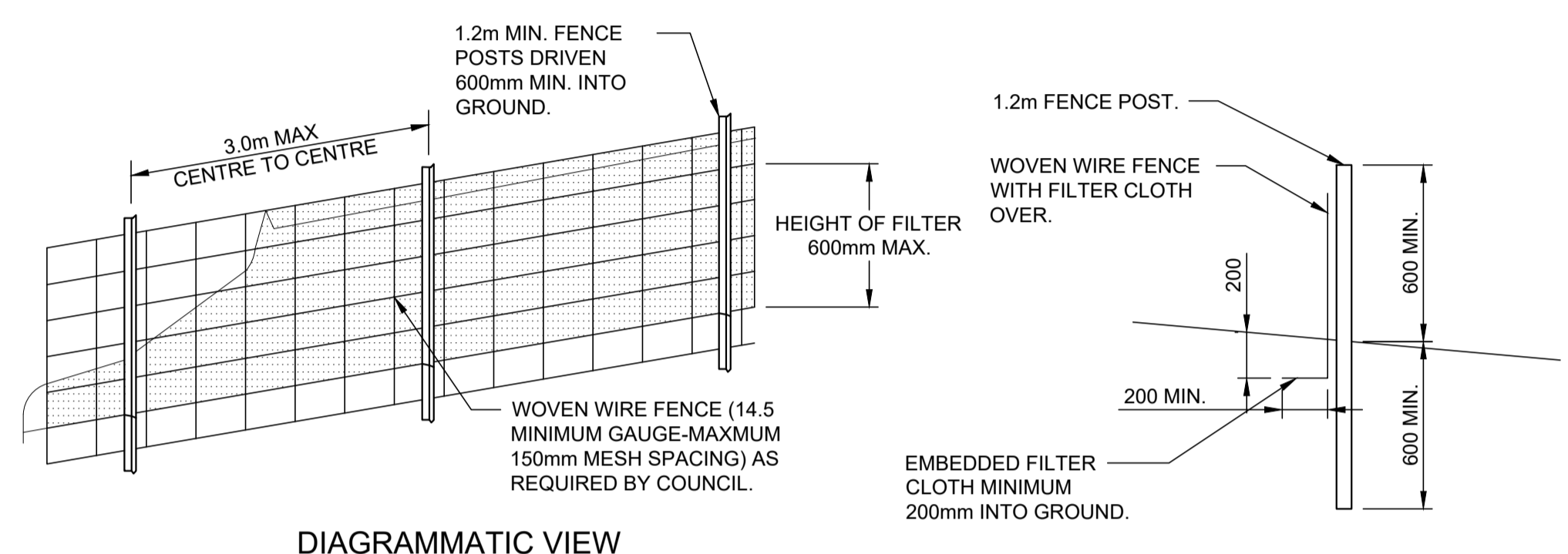

SEDIMENT FENCE DETAIL
NOT TO SCALE

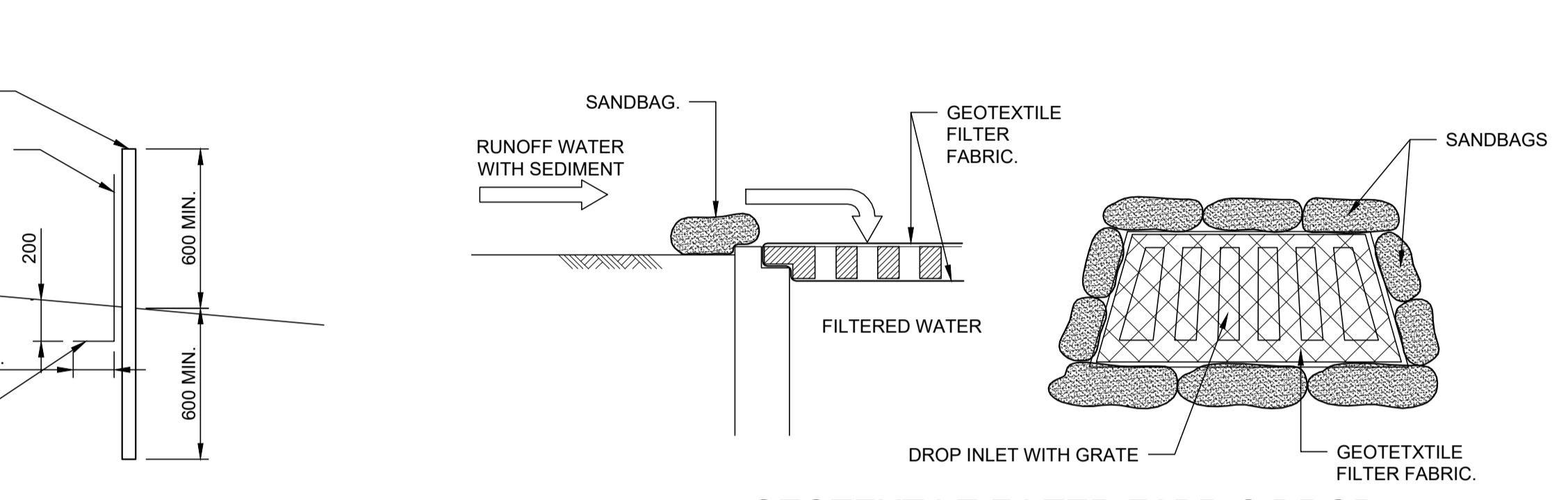

GEOTEXTILE FILTER FABRIC DROP INLET SEDIMENT TRAP
NOT TO SCALE

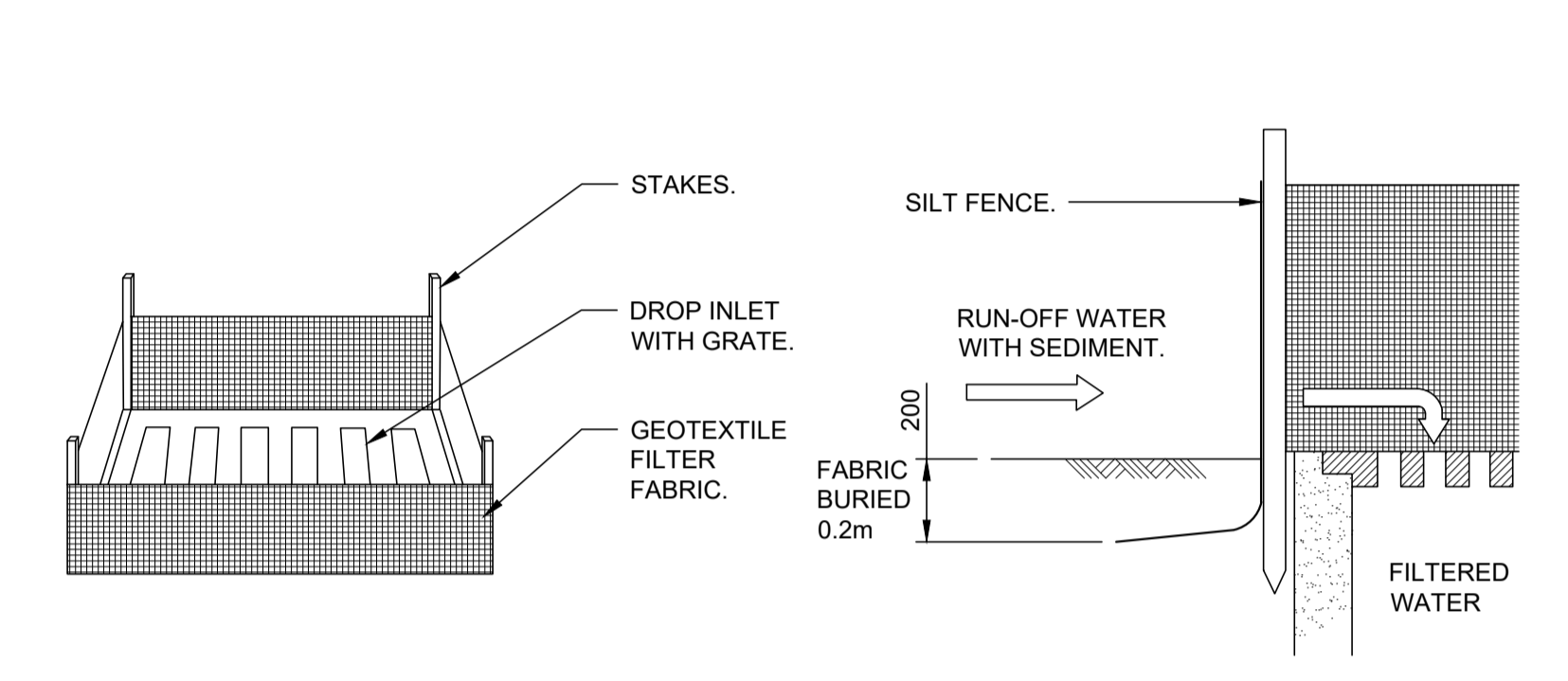

SUMP SEDIMENT TRAP DETAIL
NOT TO SCALE

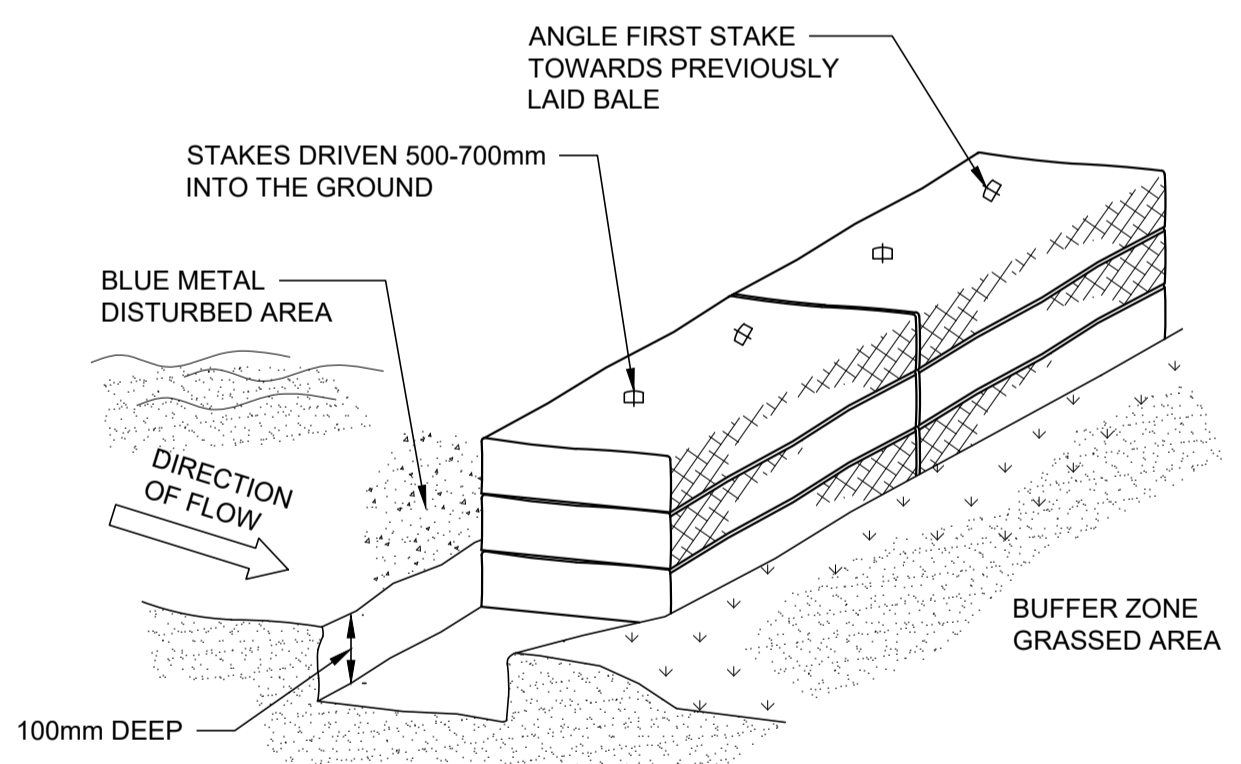

HAY BALE BARRIER DETAIL
NOT TO SCALE

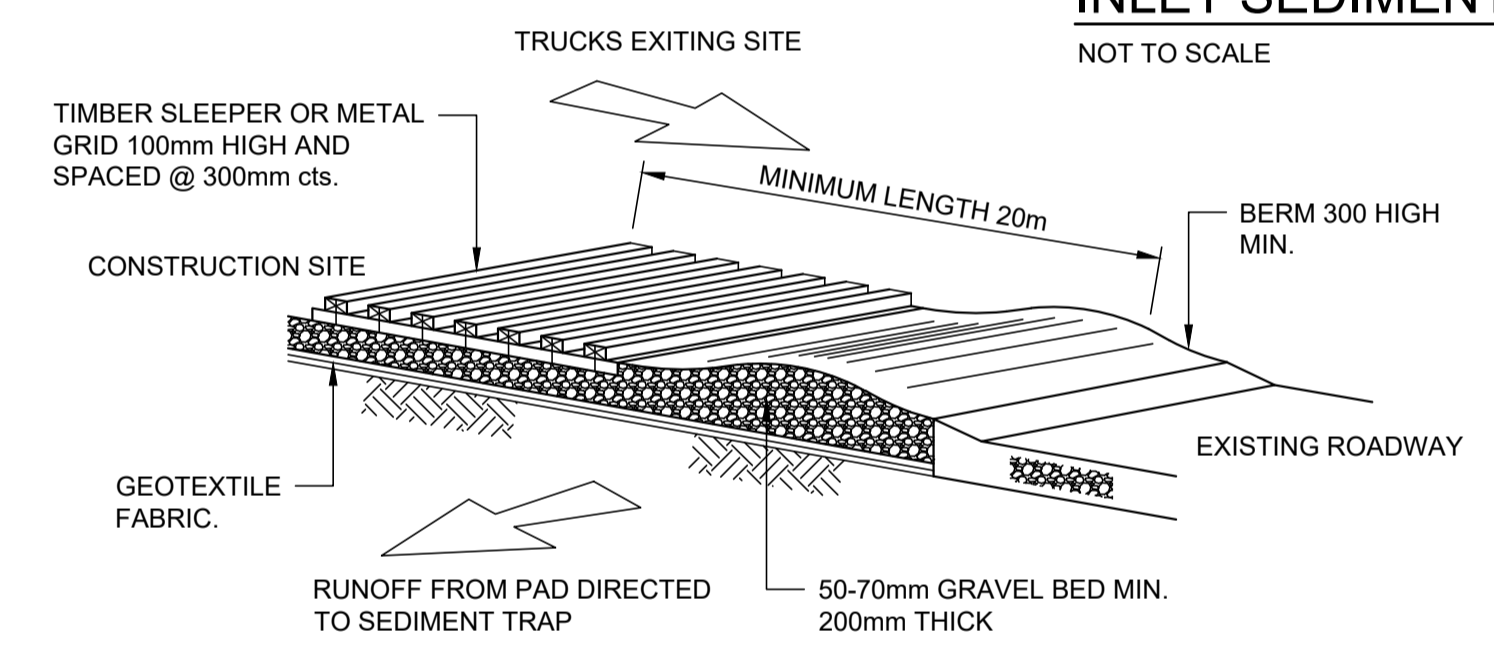

TEMPORARY CONSTRUCTION VEHICLE EXIT DETAIL
(NOT TO SCALE)

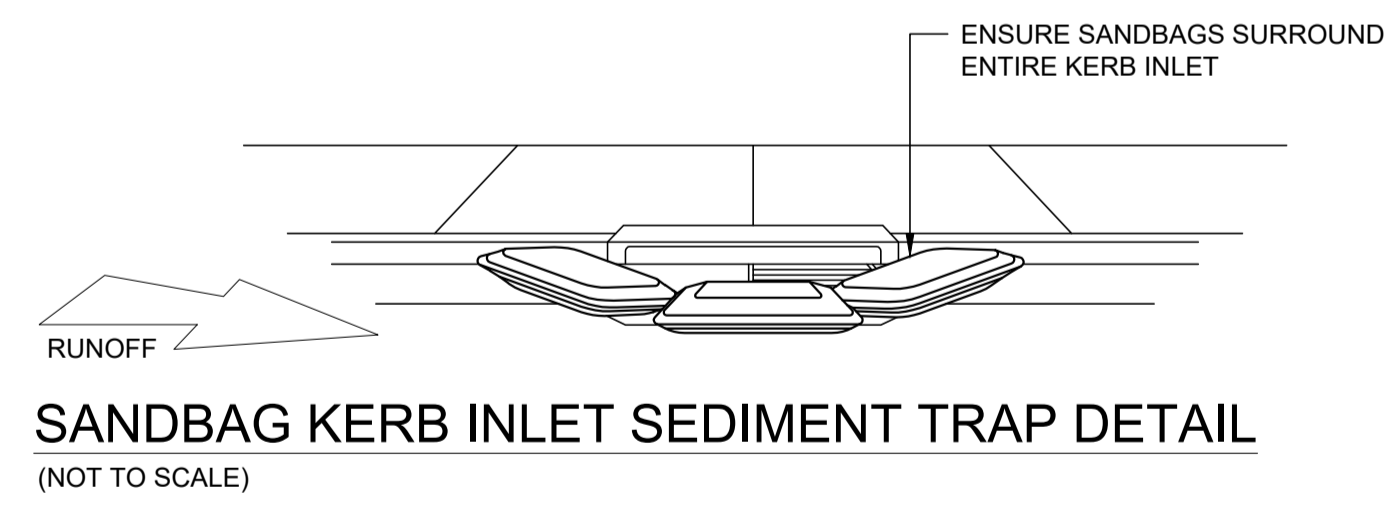

SANDBAG KERB INLET SEDIMENT TRAP DETAIL
(NOT TO SCALE)

- STOCKPILE CONSTRUCTION NOTES:**
1. PLACE STOCKPILES MORE THAN 2 (PREFERABLY 5) METRES FROM EXISTING VEGETATION, CONCENTRATED WATER FLOW, ROADS AND HAZARD AREAS.
 2. CONSTRUCT ON THE CONTOUR AS LOW, FLAT, ELONGATED MOUNDS.
 3. WHERE THERE IS SUFFICIENT AREA, TOPSOIL STOCKPILES SHALL BE LESS THAN 2 METRES IN HEIGHT.
 4. WHERE THEY ARE TO BE PLACED FOR MORE THAN 10 DAYS, STABILISE FOLLOWING THE APPROVED E.S.C.P. OR S.W.M.P. TO REDUCE THE C-FACTOR TO LESS THAN 0.10.
 5. CONSTRUCT EARTH BANKS ON THE UPSLOPE SIDE TO DIVERT WATER AROUND STOCKPILES AND SEDIMENT FENCES 1 TO 2 METRES DOWNSLOPE.

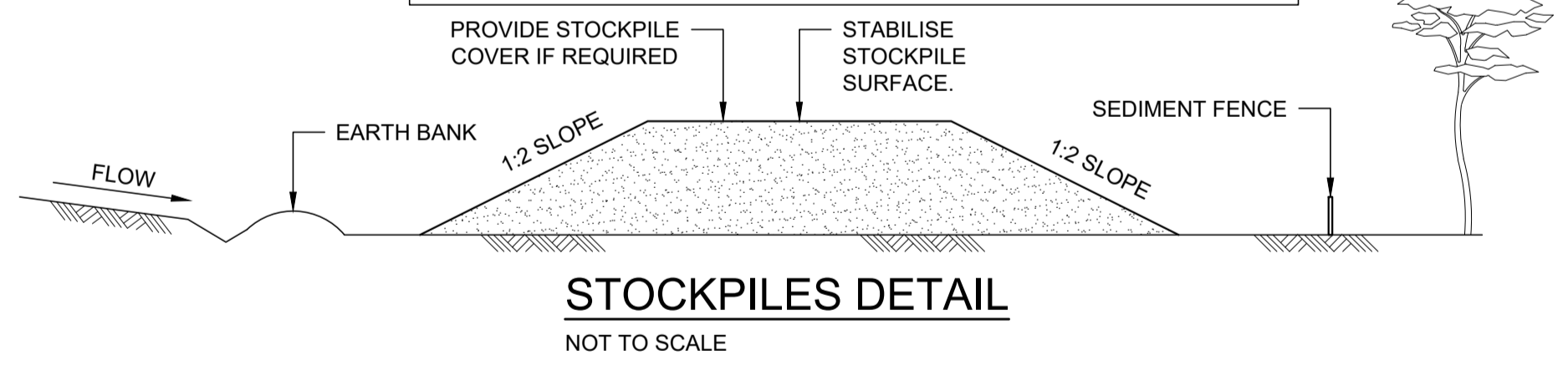

STOCKPILES DETAIL
NOT TO SCALE

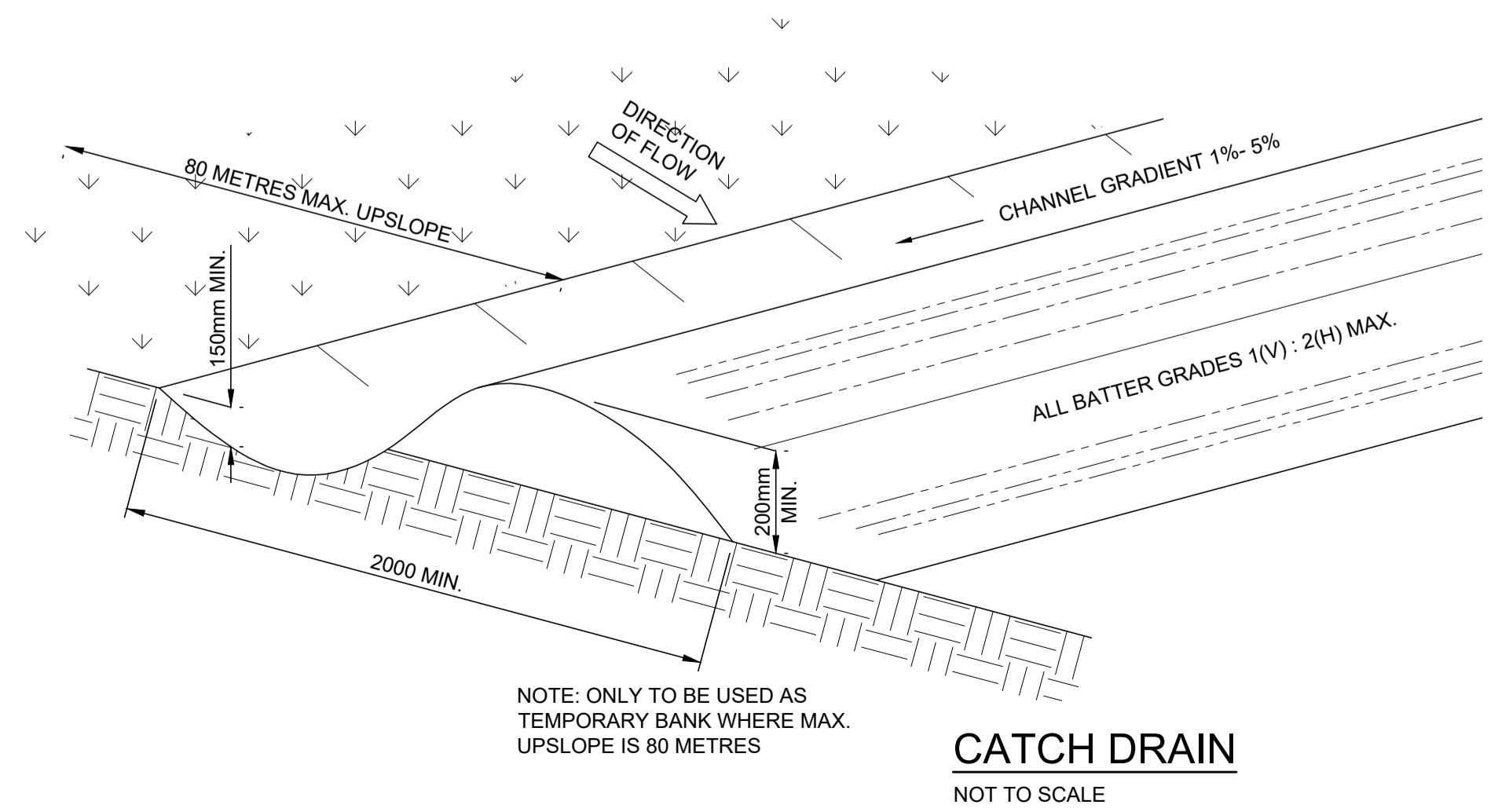

CATCH DRAIN
NOT TO SCALE

- CATCH DRAIN CONSTRUCTION NOTES:**
1. CONSTRUCT ALONG GRADIENT AS SPECIFIED.
 2. MAXIMUM SPACING BETWEEN BANKS SHALL BE 80 METRES.
 3. DRAINS TO BE OF PARABOLIC OR TRAPEZOIDAL CROSS SECTION NOT V-SHAPED.
 4. EARTH BANKS TO BE ADEQUATELY COMPACTED IN ORDER TO PREVENT FAILURE.
 5. CONSTRUCTION OF A TEMPORARY NATURE AND SHALL BE COMPACTED AT THE END A DAYS WORK OR IMMEDIATELY PRIOR RAIN.
 6. ALL OUTLETS FROM DISTURBED LANDS ARE TO FEED INTO SEDIMENT BASIN OR SIMILAR.
 7. DISCHARGE RUNOFF COLLECTED FROM UNDISTURBED LANDS ONTO EITHER A STABILISED OR AN UNDISTURBED DISPOSAL SITE WITHIN THE SAME SUBCATCHMENT AREA FROM WHICH THE WATER ORIGINATED.
 8. COMPACT WITH A SUITABLE IMPLEMENT IN SITUATIONS WHERE THEY ARE REQUIRED TO FUNCTION FOR MORE THAN 5 DAYS.
 9. EARTH BANKS TO BE FREE OF PROJECTIONS OR OTHER IRREGULARITIES THAT WILL IMPEDE NORMAL FLOW.

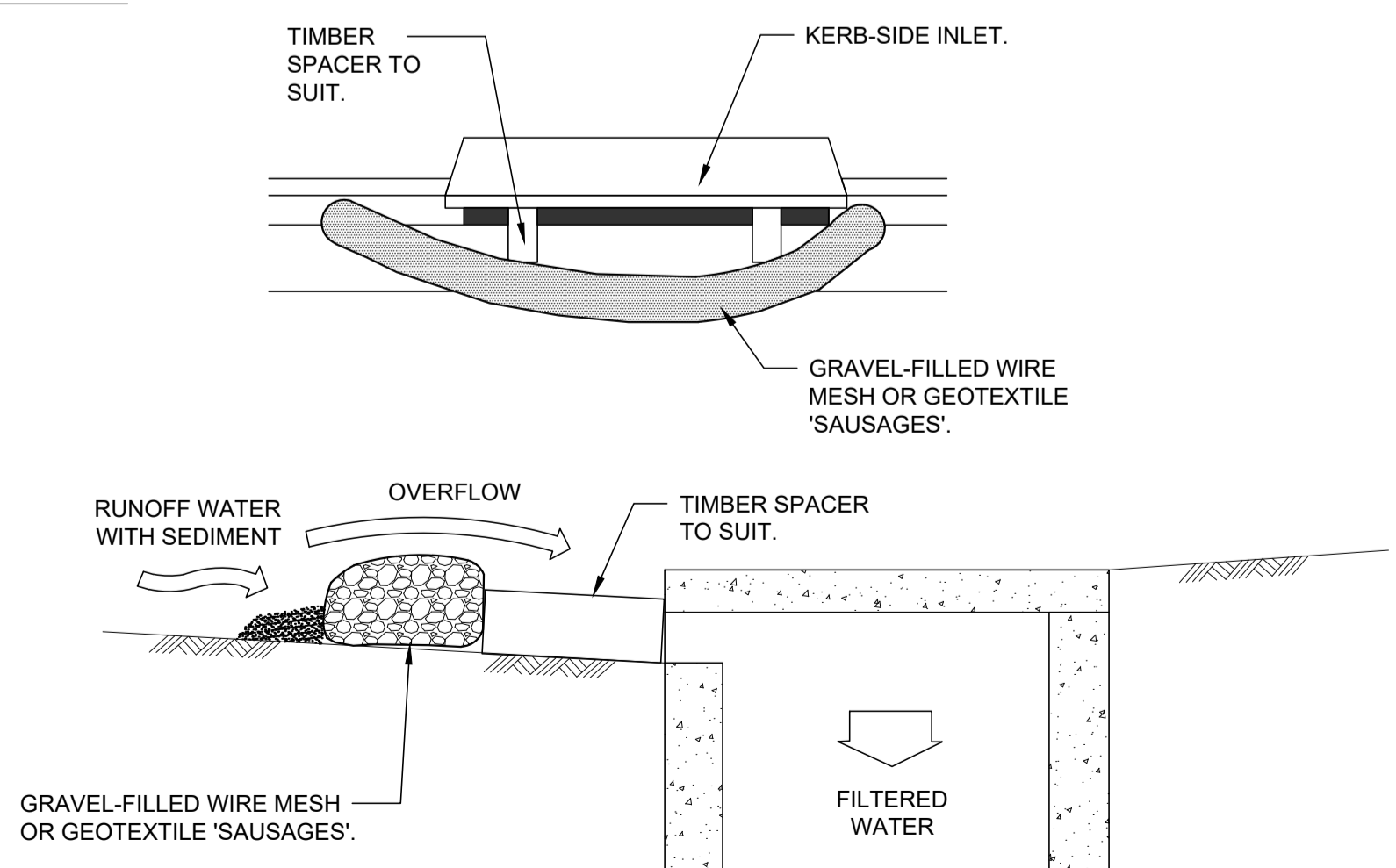

MESH AND GRAVEL INLET FILTER
SCALE 1:20

- NOTES:**
1. FABRICATE A SLEEVE MADE FROM GEOTEXTILE OR WIRE MESH LONGER THAN THE LENGTH OF THE INLET PIT AND FILL IT WITH 25mm TO 50mm GRAVEL.
 2. FORM AN ELLIPTICAL CROSS-SECTION ABOUT 150mm HIGH Ax 400mm WIDE.
 3. PLACE THE FILTER AT THE OPENING LEAVING AT LEAST A 100mm SPACE BETWEEN IT AND THE KERB INLET. MAINTAIN THE OPENING WITH SPACER BLOCKS.
 4. FORM A SEAL WITH THE KERB TO PREVENT SEDIMENT BYPASSING THE FILTER.
 5. SANDBAGS FILLED WITH GRAVEL CAN SUBSTITUTE FOR THE MESH OR GEOTEXTILE PROVIDING THEY ARE PLACED SO THAT THEY CAN FIRMLY ABUT EACH OTHER AND SEDIMENT/LADEN WATERS CANNOT PASS BETWEEN.

PRELIMINARY ISSUE
NOT FOR CONSTRUCTION

A	ISSUE FOR TENDER	05.04.24
ISSUE	DESCRIPTION	APPROVED DATE

ARCHITECT
PMDL ARCHITECTURE INTERIORS MASTERPLANNING
PMDL ARCHITECTURE + DESIGN PTY LTD ABN 66 062 186 117
NSW NOMINATED ARCHITECTS: ANDREW PENDER 3317 DAVID HERRIS 5885 VICKI VAN DIJK 9476

BIRZULIS ASSOCIATES
CONSULTING STRUCTURAL & CIVIL ENGINEERS
583 DARLING STREET ROZELLE NSW 2039
tel: (02) 9555 7230 email: office@birzulisassociates.com
www.birzulisassociates.com

PROJECT
WILLIAM CLARKE COLLEGE
10 MORRIS GROVE, KELLYVILLE
- BRYSON BUILDING

TITLE
SOIL EROSION AND SEDIMENT CONTROL DETAILS

SCALES	as noted @ A1	DATE	JULY 2023
DRAWN	C.KE	DESIGN	GK/MG
ISSUE	A	PROJECT No.	8932
		DRAWING No.	C.11

This drawing is the copyright of Birzulis Associates P/L and may not be altered, reproduced or transmitted in any form or by any means in part or in whole without the written permission of Birzulis Associates P/L. All levels and dimensions are to be checked and verified on site prior to the commencement of any work, making of shop drawings or fabrication of components. Do not scale drawings. Use Figure Dimensions.

William Clarke College

COMMUNITY COMMUNICATION STRATEGY

BRYSON BUILDING CONSTRUCTION WORKS

September 2024



Indicative Artist's impression of proposed concept design (source: EIS Summary)

Question today *Imagine tomorrow* Create for the future

William Clarke College
Community Communication Strategy
Masterplan - Bryson Building construction works (SSD-35715221)

WSP
Level 27, 680 George Street
Sydney NSW 2000
GPO Box 5394
Sydney NSW 2001

Tel: +61 2 9272 5100
Fax: +61 2 9272 5101
wsp.com

Rev	Date	Details
1	3 September 2024	Draft
2	4 September 2024	Issue to client
Final	9 September 2024	Review and reissue based on client feedback

WSP acknowledges that every project we work on takes place on First Peoples lands.
We recognise Aboriginal and Torres Strait Islander Peoples as the first scientists and engineers and pay our respects to Elders past and present.

This document may contain confidential and legally privileged information, neither of which are intended to be waived, and must be used only for its intended purpose. Any unauthorised copying, dissemination or use in any form or by any means other than by the addressee, is strictly prohibited. If you have received this document in error or by any means other than as authorised addressee, please notify us immediately and we will arrange for its return to us.



Table of contents

William Clarke College	
COMMUNITY COMMUNICATION	
STRATEGY 1	
1	Introduction 1
1.1	About the project..... 1
1.2	Site location 1
1.3	Objective of this strategy..... 2
1.4	Community liaison 3
2	Stakeholder analysis..... 7
2.1	Key stakeholders and approach 7
3	Engagement tools and timeframes 10
3.1	Tools and timeframes 10
4	Administration and record keeping 12
5	Distribution area 13

1 Introduction

1.1 About the project

William Clarke College has developed a Masterplan outlining how the college intends to upgrade the campus to improve or replace buildings and reconfigure the site to meet current educational needs. These changes are intended to allow the college to continue to deliver high quality educational outcomes for years to come, increase student enrolment, and improve the environmental sustainability of the campus.

This project meets the definition of a State Significant Development (SSD) and has received development consent on 20th October 2023 (SSD-35715221)

This project and plan refers to Stage 1 works. These are associated with the overall school Masterplan as was outlined in the EIS. Stage 1 works consists of construction of a new building – the Bryson Building

This Strategy has been prepared as a requirement of the development consent for SSD-35715221 to support the delivery of the ‘Bryson Building’.

1.2 Site location

William Clarke College is located at 1 Morris Grove, Kellyville NSW 2155 which falls within the Hills Shire Council LGA.

The Bryson Building will be constructed within the school campus as shown in the layout below and as described in the EIS summary.

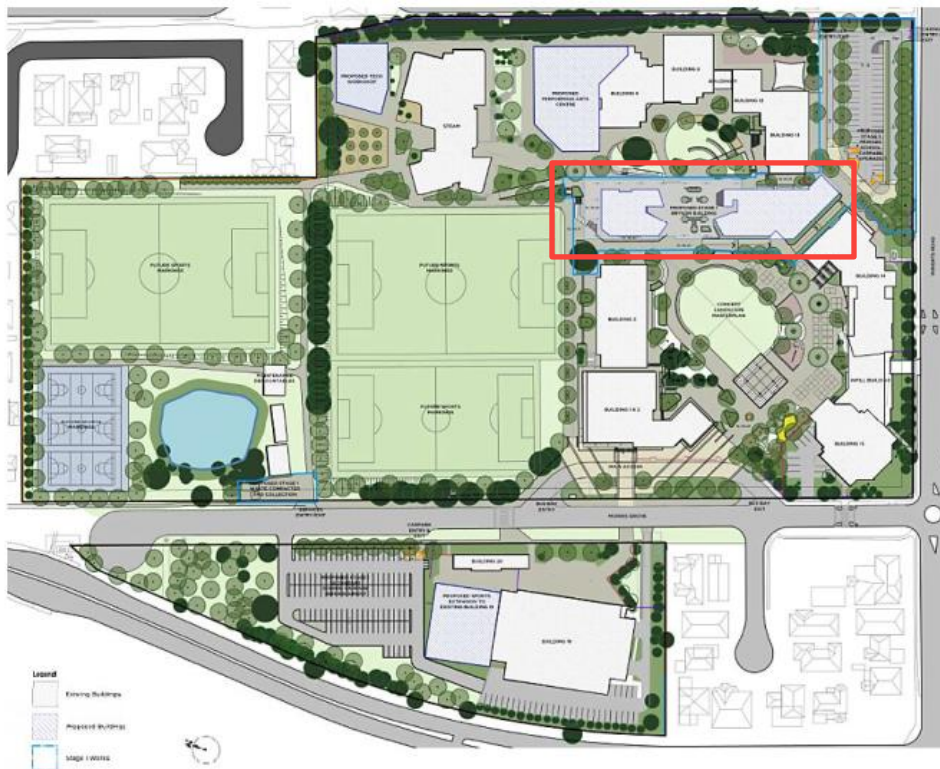

Source: EIS Summary – Masterplan Stage 1 – Bryson Building outlined in red

1.3 Objective of this strategy

Construction communications will build on communications and engagement undertaken during the planning phase. Rohrig and the school have a continued commitment to maintain clear and proactive communications with neighbours and stakeholders, maintaining reputation, meeting planning and council expectations and supporting the timely delivery of the project. Building on the engagement activities outlined in Appendix J of the EIS, this Communication strategy will guide continued proactive open, honest and clear lines of communication.

The strategy has been developed to meet the requirements of the Development Consent conditions for SSD-35715221 and will support the delivery of requirements in the Construction Environmental Management Plan (CEMP) and any consultation required to mitigate impacts as planning and on-site work.

This Community Communications Strategy has been developed to achieve the following community engagement objectives:

- guide community communications for the project in the lead up to, during and for a minimum of 12 months following completion of construction
- meet the requirements of the Development Consent
- provide timely information to impacted stakeholders, the college community, and the broader community
- communicate the benefits of the project
- build on the college community stakeholder relationships and maintain goodwill with the surrounding community
- manage community expectations and build trust by delivering on commitments
- address and correct misinformation in the public domain
- reduce the risk of project delays
- align with the communications activities and objectives of the delivery of the Masterplan
- recognise that construction of the Bryson Building forms part of a wider and ongoing conversation with stakeholders about the Masterplan and proposed campus upgrades.
- allow the college to carry out the bulk of the engagement activities without the need for third-party support.

As per condition C8 of the Development Consent (SSD-35715221) this Community Communication Strategy is to be issued two weeks before the commencement of any construction to the Planning Secretary for information.

1.3.1 Plan compliance

As per the requirements set out in the Development Consent SSD-35715221 the below requirements are addressed within this plan.

Condition	Requirement	Plan Section
C9 (a)	Identify people to be consulted during the design and construction phases;	2 Stakeholder analysis
C9 (b)	Set out procedures and mechanisms for the regular distribution of accessible information about or relevant to the development	1.4 Community liaison

C9 (c)	Provide for the formation of community-based forums, if required, that focus on key environmental management issues for the development;	3 Engagement tools and timeframes
C9 (d)	Set out procedures and mechanisms: (i) through which the community can discuss or provide feedback to the Applicant (ii) through which the Applicant will respond to enquiries or feedback from the community (iii) to resolve any issues and mediate any disputes that may arise in relation to construction and operation of the development, including disputes regarding rectification or compensation.	1.4 Community liaison and 3.1 Tools and timeframes
C9 (e)	Include any specific requirements around traffic, noise and vibration, visual impacts, amenity, flora and fauna, soil and water, contamination, heritage.	This plan and project CEMP and sub plans

1.4 Community liaison

Building on the engagement activities carried out to date, William Clarke College will ensure a point of contact is established with responsibility for community liaison in collaboration with the construction project manager and project contractors. The purpose of this is to proactively keep the local community and the college community informed about:

- what to expect during construction
- timing
- changes to works schedule
- potentially impactful works including disruptions due to noise, vibration, loss of parking, or truck movements
- how to make contact with questions about the development and to raise concerns or provide feedback.

1.4.1 Responsibilities

1.4.1.1 William Clarke College

- Provide point of contact for queries about the development and future operations and provide alternative point of contact for construction related queries (Construction Contractor to be first point of contact)
- Communications channels for William Clarke College include:
 - Email dej@wcc.nsw.edu.au
 - Phone +61 2 8882 2100
- Proactively communicate project milestones
- Respond to community and stakeholder questions and feedback during construction and operations.
- Maintain a Complaints Register which will be uploaded to the website and updated monthly during construction.
- Ensure relevant project documentation is uploaded to the College website as required by the Planning Secretary.

1.4.1.2 Construction contractor

- Provide point of contact for construction related queries.
- William Clarke College will be informed of any community contact and complaints will be passed on for response as required. Feedback received will be shared. A register contact will be maintained.
- Responsible for construction signage and wayfinding and construction notifications if required related to road closures, remediation, out-of-hours works etc.

1.4.1.3 Post construction / operations

- Following construction and during operations, any queries will be responded to by a representative of William Clarke College.
- The college has a formal internal and external community queries contact and resolution process in place to facilitate effective response processes which is ongoing.

1.4.2 *Boarder community engagement*

William Clarke College may carry out community engagement activities about Stage 1 works more broadly, such as the activities outlined in Appendix J of the EIS. This strategy has been prepared to exist concurrently and in collaboration with any broader engagement activities.

1.4.3 *How to find out more or share feedback*

William Clarke College will ensure a point of contact is established with responsibility for community liaison in collaboration with the project manager and project contractors.

Communications and engagement will be targeted according to level of interest:

- immediate neighbours
- stakeholders who have previously demonstrated a level of interest in the Masterplan and capital works
- wider community
- college community some of whom are also neighbours.
- Hills Shire Council

1.4.3.1 All community and stakeholders

Community updates

- As the project progresses to the pre-construction phase the first community update will be shared. This update will provide the immediate neighbours, wider community and stakeholders with an overview works, an indicative timeline, contact information, and likely impacts.
- Community updates will be provided throughout construction at key milestones.

Website updates

- The project website will be used as a key point for information about the project and construction and will be proactively kept up to date as work progresses. All communications will provide links to the [website](#).

- At least 48 hours before the start of construction and until completion of all works under the Development Consent (condition A26), or such other time as agreed by the Planning Secretary, the following information and documents (as they are obtained or approved) must be made publicly available on the website:
 - the documents referred to in Schedule 3 condition A2 of the Development Consent
 - all current statutory approvals for the development
 - all approved strategies, plans and programs required under the conditions of the Development Consent
 - regular reporting on the environmental performance of the development in accordance with the reporting arrangements in any plans or programs approved under the conditions of the Development Consent
 - a comprehensive summary of the monitoring results of the development, reported in accordance with the specifications in any conditions of the Development Consent, or any approved plans and programs
 - a summary of the current stage and progress of the development
 - contact details to enquire about the development or to make a complaint
 - a complaints register - updated monthly
 - audit reports prepared as part of any independent audit of the development and the College's response to the recommendations in any audit report
 - any other matter required by the Planning Secretary.

This information is to be kept up to date, to the satisfaction of the Planning Secretary, and publicly available for 12 months after the commencement of operations.

Construction notifications

- Works notifications will be issued as required ahead of potentially impactful works e.g. traffic changes, out-of-hours work etc., these will include contact details for queries and complaints.
- Doorknock / call to support notification as required.

Signage

- Works signage will be prepared and displayed as required to ensure safety and communicate contact details.

Contact us

The point of contact details for questions and feedback will be communicated to the local community and key stakeholders ahead of the commencement of works via community newsletter letterbox drop, direct contact where community members had asked to be kept up to date.

1.4.4 Complaints and Enquiries Register

William Clarke College will maintain a register of complaints and enquiries received and will take all reasonable steps to investigate and close out complaints and enquiries in a timely manner.

A complaints register with date and type of complaint, and whether the complaint is open or closed, will be uploaded to the college website (development consent condition A26).

1.4.5 *Dispute Resolution*

Should any complaints and enquiries received by the construction contractor require escalation, they will be referred to the nominated contact at William Clarke College in the first instance who will escalate via the Principal and College Board if required.

1.4.6 *Media*

All media queries are to be referred to dej@wcc.nsw.edu.au

2 Stakeholder analysis

2.1 Key stakeholders and approach

Stakeholders can be categorised in two distinct groups - external and internal.

The below table lists the various groups that fall within these two overarching categories and outlines their likely interest, interest level and suggested engagement techniques to best communicate with them during the project lifetime.

2.1.1 External Stakeholders

Stakeholder	Likely interest	Interest level	Engagement techniques
External			
Immediate neighbours	<ul style="list-style-type: none"> » Construction impacts – dust, noise and vibration, traffic and parking. » Design and operations - building bulk and scale, hours of operation. » Privacy » Traffic impacts and truck movements 	High	<ul style="list-style-type: none"> » Early engagement » Community updates, project website » Letterbox drop – works notification, community updates » Community liaison contact details » Signage » Doorknock – if required
Nearby residents and any stakeholders engaged during planning phases	<ul style="list-style-type: none"> » Traffic impacts on local roads » Construction impacts such as noise, dust and vibration 	High / medium	<ul style="list-style-type: none"> » Community updates, project website » Letterbox drop – works notification, community updates
Community members listed on college contact register for relevant updates	<ul style="list-style-type: none"> » Operations » Availability of a point of contact to direct issues / questions 		<ul style="list-style-type: none"> » Community liaison contact details » Signage » Doorknock – if required
Wider community	<ul style="list-style-type: none"> » Traffic impacts » Operations » Availability of a point of contact to direct issues / questions 	Medium / low	<ul style="list-style-type: none"> » Community updates, project website
Hills Shire Council	<ul style="list-style-type: none"> » Community concern » Impact on local traffic » Impact on condition of local roads » Availability of a point of contact to direct issues / questions 	Medium	<ul style="list-style-type: none"> » Direct contact » Include in notifications distribution list » Community liaison contact details

2.1.2 Internal stakeholders

Stakeholder	Likely interest	Interest level	Engagement techniques
Internal			
Engagement techniques would be informed by usual college processes, but could include the following:			
William Clarke College staff	<ul style="list-style-type: none"> » Impact on normal college operations » Construction impacts such as noise, dust and vibration » Safety of students » Parking impacts 	High	<ul style="list-style-type: none"> » Staff briefings ahead of start of work and ongoing at key milestones where impacts change » Internal college communications channels could include: <ul style="list-style-type: none"> — email via Principal / Executive — notifications posted to staff notice boards — intranet — distribution of project notifications. Newsletters — website - project page » Signage and barriers » Traffic and pedestrian controllers as required
Students	<ul style="list-style-type: none"> » Impact on normal college operations » Construction impacts such as noise, dust and vibration » Safety of students » Pedestrian safety 	High	<ul style="list-style-type: none"> » Internal college communications channels could include: <ul style="list-style-type: none"> — ‘what to expect’ briefing — newsletters — announcements — emails — teaching staff — noticeboards — website - project page » Signage and barriers » Traffic and pedestrian controllers as required
William Clarke College Parents Association	<ul style="list-style-type: none"> » Impact on normal college operations » Construction impacts such as noise, dust and vibration » Safety of students 	High	<ul style="list-style-type: none"> » Could include: <ul style="list-style-type: none"> — briefings ahead of start of work and ongoing at key milestones where impacts change — website updates — signage and barriers — traffic and pedestrian controllers as required

			<ul style="list-style-type: none"> — email via Principal / Executive — construction notification — college newsletter
William Clarke College parents	<ul style="list-style-type: none"> » Impact on normal college operations » Construction impacts such as noise, dust and vibration » Safety of students 	High	<ul style="list-style-type: none"> » Could include: <ul style="list-style-type: none"> — via Parents Association — website updates — email via Principal/ Executive — construction notification — college newsletter » Signage and barriers » Traffic and pedestrian controllers as required

Construction contractors will work closely with the William Clarke College to ensure the college community is kept informed of any safety measures in place including changes to internal and external pedestrian and vehicle access and restricted areas.

The college will be responsible for its internal communications informed by ongoing updates from the contractors. Barriers, signage, notifications would be the responsibility of the contractor

3 Engagement tools and timeframes

The Strategy outlines procedures and mechanisms for distribution of information to stakeholders. Effective communication between the project team and stakeholders serves as a risk mitigation tool, and also supports both the project team and stakeholders to achieve positive outcomes in relation to the project.

3.1 Tools and timeframes

Collateral content will be informed by the Construction & Environmental Management Plan (CEMP) which provides key information about ‘what to expect during construction.’

Engagement tool	Who	Why	When
Contact number and email address	» Interested external community and stakeholders	» Provide point of contact for community and stakeholders to provide feedback or raise concerns around the project	» Establish prior to start of works
School Website https://www.wcc.nsw.edu.au/2022/04/01/community-consultations-the-bryson-building/	» Interested external community and stakeholders » Parents and students » Meet Development Consent requirements	» Build awareness of project » Provide up to date project information point for all » Provide update on project milestones	» At least 48 hours prior to start of works provide information and documentation as directed by the Development Consent » Immediately prior to start of works to advise what to expect during construction and provide contact details » Updated throughout project » Add any newsletters or notifications
Direct contact Call / email / meeting	» William Clarke College Parents Association » Govt agencies » Hills Shire Council	» Provide project information including potential impacts	» Immediately prior to start of works to advise what to expect during construction and provide contact details » Communicate project milestones
Letterbox drops – doorknocks may be undertaken if required	» Nearby residents	Proactively advise: » start of construction commencing, providing contact details for updates and queries	» Immediately prior to start of works to advise what to expect during construction and provide contact details
Newsletters Notifications		» of any works that may produce extreme noise/vibration / dust	» Communicate project milestones

Engagement tool	Who	Why	When
		<ul style="list-style-type: none"> » of any hazardous materials removal » about major project milestones » project completion 	
Ad-hoc meetings	» Nearby residents	» In response to concerns if required	» As required
The following may form part of internal communications			
College internal communications channels	» Staff	» Provide staff with project updates specific to day to day activity	<ul style="list-style-type: none"> » Immediately prior to start of works to advise what to expect during construction and provide contact details » Updated throughout project » Add any newsletters or notifications
‘What to expect’ briefing	» Staff	Proactively advise:	» Prior to start of works to advise what to expect during construction and provide contact details
Newsletters	» Students	» start of construction commencing, providing contact details for updates and queries	» Throughout work
Announcements	» Parents		
Emails			
Noticeboards		<ul style="list-style-type: none"> » changes to access and movement » any safety information » of any works that may produce noise/ vibration / dust » of any hazardous materials removal » about major project milestones » project completion 	

4 Administration and record keeping

Record keeping and reporting throughout engagement will:

- Acknowledge contact and respond to all issues within 72 hours
- Advise any issues as identified
- Establish and apply escalation protocols – safety being a priority.
- Establish a follow up reminder mechanism to ensure agreed actions are carried out.
- Establish and maintain a stakeholder list for ongoing communications as communications progress.
- Report activities undertaken as well as outcomes.

5 Distribution area

Consistent with engagement activities already carried out, this strategy will use the same distribution area represented in Appendix J of the EIS.



Community update distribution area map (source: six maps)

Emergency Management Plan



Table of Contents

1. Definitions..... 3

2. Introduction..... 3

 2.1 Review and Amendment 3

3. Response Strategies..... 4

4. Administration and Logistics..... 5

5. Command and Communications..... 5

6. Evacuation Response 5

7. Temporary Closure Response 6

8. Site Signage..... 7

9. Emergency Numbers..... 8

10. Types of Training..... 8

 10.1 Apply First Aid..... 8

 10.2 Apply Advanced First Aid 8

 10.3 Manage First Aid in the Workplace (Occupational First Aid) 9

 10.4 Additional training for first aiders..... 9

 10.5 First Aid & Site Emergency Equipment Assessment 9

 10.5 ECO Training 9

11. Emergency Equipment..... 9

12. Emergency Response Requirements 10

13. Critical Incident Investigation 11

14. Specific Emergency Response Requirements and Scenarios 11

15. Emergency Plan Checklist 18

1. Definitions

Term	Comment
Alarm	is a signal giving warning of danger.
Assembly Area	is a designated location used for the assembly of emergency-affected persons.
Biological hazard	includes infectious and cytotoxic waste
BOM	Bureau of Meteorology
Bushfire	is a fire involving grass, scrub or forest.
Cardiopulmonary resuscitation (CPR)	A resuscitation technique that combines expired air resuscitation with external cardiac compression
Casualty	is an injured person, a person killed or injured as the result of the incident or emergency
Compound	is an area bounded by natural ground contours or by a bund and intended to retain spillage or leakage.
Critical incident	is defined by the National Code of Practice for Construction (FWBC) as 'a traumatic event, or the threat of such, which causes extreme stress, fear or injury'.
Cyclone warning	is a message released by a tropical cyclone warning centre (TCWC) when the existence of a cyclone or a developing disturbance with potential to develop into a cyclone exists and is expected to cause at least gale force winds in coastal areas within 24 hours.
Director	The person ordinarily in day-to-day charge of the company.
Emergency	is an event, actual or imminent, which endangers or threatens to endanger life, property or the environment, and which requires a significant and coordinated response. Any event which arises internally or from external sources which may adversely affect the safety of persons in a building or the community in general and requires immediate response by the occupants.
Emergency control organisation (ECO)	A structured organisation which will organise an appropriate response to emergency situations.
Emergency management	is a range of measures to manage risks to people, communities and the environment.
First aid	is immediate and temporary care given on site to the victims of an accident or sudden illness in order to avert complications, lessen suffering and sustain the person until competent services or a physician can be obtained.
Flammable liquid	is a liquid which is capable of being ignited and burning in air and which meets the criteria of the ADG Code.
Flood	is the overflowing by water of the normal confines of a stream or other body of water, or the accumulation of water by drainage over areas which are not normally submerged.
Hazardous chemical	is a chemical which: a) is listed on the National Occupational Health and Safety Commission's List of Designated Hazardous Chemicals (b) has been classified as a hazardous chemical by the manufacturer or importer in accordance with the National Occupational Health and Safety Commission's Approved Criteria for Classifying Hazardous Chemicals.
Hierarchy of Control	Control measures that should be used to reduce the risk of a workplace accident, including 'elimination', 'substitution', 'isolation', 'engineering control', 'administrative control', and, 'personal protective equipment'.
Ignition source	includes heat, sparks, flames, static electricity and friction.
Natural disaster	is any emergency defined by the Commonwealth for the purposes of the Natural Disaster Relief Arrangements: bushfires, cyclones, earthquakes, floods and storms including hail.
Paramedic	is an ambulance officer with advanced life support skills.
Personal protective equipment	is the equipment necessary to shield or isolate a person from the chemical, physical and thermal hazards that may be encountered at a dangerous goods incident.
Poison	is a substance that, when introduced in sufficient quantity into an animal organism by ingestion, inhalation or absorption, destroys or threatens to destroy life or injures health.
Risk assessment	is the process used to determine risk management priorities by evaluating and comparing the level of risk against predetermined standards, target risk levels or other criteria.
Safety data sheet (SDS)	A document that describes the properties and uses of a chemical, that is, identity, chemical and physical properties, health hazard information, precautions for use and safe handling information.

2. Introduction

The purpose of this Emergency Response Plan (ERP) is to provide details of how Rohrig will prepare for and respond to a disaster or emergency situations. This includes weather, geological, biological or human events that pose risks to life, property or the environment. Any records and documentation associated with this procedure must be maintained in accordance with legislative requirements and record keeping processes.

2.1 Review and Amendment

This Emergency Management Plan (EMP) is only valid on the last date of distribution; it currently resides locally with the author who should be contracted if you are in doubt of the authenticity or currency.

This EMP shall be reviewed:

- When there is a change in project scope that relates to or may change the:
 - Work health and safety risks.
 - Environmental risks.
 - Quality risks; and/or
 - Information security risks
 - of this project and the control measures in place to avoid or mitigate those risks; or
 - An incident or non-conformance takes place; or
- An improvement is identified through either on-site experience, audits or change in industry best practice; or
- There is a change to applicable legislation, standards, codes of practice or Rohrig procedures; or
- At scheduled intervals, depending on the phases and duration of the project, recommended monthly (to align with the project WHS Management Plan).

By signing the below, I agree to have the appropriate qualifications and experience to enact my responsibilities under this plan.

Initial Approval & Review				
EMP	Name	Position	Signature	Date
Created by:	Tim Gillespie	Senior Safety Consultant		
Approved by:	Dave Campbell	General Manager		
Project Manager	Brad Blanshard			
Site Manager	Andries van der Walt			
Fire Warden	Andries van der Walt			
First Aider	Andries van der Walt			

REGISTER OF AMENDMENTS			
<i>NOTE: Upon review where there have been no amendments to the EMP, the table below shall be dated with the words 'no changes noted'. Consultation with all stakeholders shall be conducted if there are any amendments to the EMP. This shall be communicated via morning Pre-start or a Toolbox meeting</i>			
Date	Version No	Description of Amendments	Approved by
28/08/2024	1	Initial Release	

3. Response Strategies

When a facility is impacted, or is about to be impacted, by a disaster or emergency this plan will be enacted at the direction of the Site Manager. Each disaster or emergency may have extenuating circumstances which require the application of an additional appreciation to provide a solution to new risk or circumstance.

Rohrig has adopted an 'all hazards approach' to the planning of response strategies to disasters or emergencies and subsequently there are generally three response strategies that can be implemented prior to or during a disaster or emergency.

The general response strategies, which can be implemented singularly or jointly, are:

- Evacuation of the facility;
- Lockdown of the facility;
- Temporary Closure of the Facility

It is also noted that disasters or emergencies may also be categorised as:

- 'rising tide' or 'slow burn' events which enables decision makers to act prior to the impact of the event; or
- sudden or spontaneous events for which there are no warnings or indications that allow pre-emptive actions, and the vent must be responded to during or post impact.

Disasters or emergencies may occur under such circumstances that the Fire Warden can make pre-emptive decisions to take action and best prepare staff or business for the event. This is the preferred scenario for Rohrig in that when a disaster or emergency is identified as having a potential impact on Rohrig the Fire Warden can begin preparations as early as practicable with a view to ensuring the safety of staff and other stakeholders.

4. Administration and Logistics

The Coordination Centre is to be located at the office where the Fire Warden and Response Team (RT) will operate if practicable, for this project it will be the site office. This facility has the requisite support for occupation, communications capability and other resources for the response structure.

Hard copies of this Emergency Management Plan should be stored in the site office, held by the Fire Warden and other staff who form part of the Response Team.

5. Command and Communications

The Fire Warden will form, and chair, the Response Team, also known as emergency control organisation (refer to OP09 Emergency Management Procedure). The FW is responsible for making decisions about the temporary closure and re-opening of the business.

When formed, the RT is to establish and maintain communications with any external stakeholders (such as business partners, shareholders, franchise owners, other locations) as practicable. In the absence of communications, the FW must operate independently until communications are able to be established.

The Response Team has been included within the [Emergency Numbers](#) section of this EMP.

Some offices or locations due to their size will not have the staff to fill the suggested positions and available staff will have to undertake multiple roles. A list of key contacts is included in this EMP. It lists the response entities and mechanisms to assist communications before, during or after an event. It also lists other agency and stakeholder contact points.

6. Evacuation Response

Priority	Safety of staff, members of the community and/or site visitors.
Reporting the emergency	Contact Emergency Services immediately on 000 Notify the Director
Evacuation	<p>Signal <u>Emergency Alert Signal</u></p> <p>This signal is given to make others in the immediate vicinity aware that an emergency is commencing. On hearing the signal workers should prepare to evacuate. Raise the alarm by shouting “Fire, Fire, Fire”, or “Emergency, Emergency, Emergency” or by, Sounding the alarm or air horn three times at 3 second intervals for 3 seconds (i.e.: three seconds on, three seconds off, three times.)</p> <p><u>Emergency Evacuation Alarm</u></p> <p>On hearing this alarm workers shall evacuate to the “site assembly point” Raise the alarm by shouting “Evacuate, Evacuate, evacuate” or by Sounding the alarm or air horn for a continuous 10 second blast three times.</p> <p><u>Medical Emergency</u></p> <p>Contact the site first aider via telephone. If this is not an available option get the attention of other workers by shouting “Emergency, Emergency, Emergency”.</p>













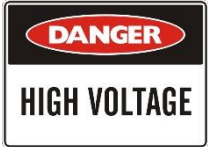

	<p>Procedure</p> <p>Remain calm.</p> <p>Proceed to the Site Assembly Point</p> <p>Ensure persons in your immediate vicinity are aware they must evacuate to the Site Assembly Point</p> <p>Assist any persons having trouble with the evacuation (personnel in distress or with a disability)</p> <p>If the evacuation is in response to fire, and it is safe to do so, close doors and windows behind you as you leave the building.</p> <p>Remain at the designated Site Assembly Point and wait for instruction from the Fire Warden.</p> <p>Account for all site personnel by checking Evacuation Lists / Registers</p> <p>Report missing personnel to the Fire Warden.</p> <p>Remain at the designated Site Assembly Point area until instructed to return to work or move to another area.</p> <p>Do not put yourself or others at risk</p>
	<p>Assembly procedure</p> <p>Head count is conducted for all workers.</p> <p>Report all staff/persons unaccounted for to the Director (or delegate).</p>
Evacuation clearance	<p>No person is to return to any area of the workplace until advised by the Director.</p> <p>One blast on the alarm is the clearance signal.</p>
General principles	<p>Evacuation procedures will be displayed on Emergency Evacuation maps in all rooms.</p> <p>FIRST PRIORITY is to the safety of staff in the workplace.</p> <p>ALL staff and visitors are automatically involved.</p> <p>CONTRACTORS should sign the Visitors book at the site office.</p> <p>NO person should be placed in a position of risk.</p> <p>EVACUATION drill will be conducted at least annually at Rohrig offices and every 3 months on a Rohrig construction site. Annual revision of the use of Fire Extinguishers will be conducted.</p> <p>DIRECTOR OR DELEGATE is responsible for ensuring the electricity is turned off and that Emergency Services are contacted and given every assistance.</p>
Communications	<p>If the evacuation goes for an extended time, then Fire Warden to inform the workers and stakeholders via the established formats.</p>
Pre-arrangements	<p>Site Emergency Evacuation Maps must be clearly displayed at site office and or lunchrooms.</p> <p>Visitor sign-in registers maintained in the site office.</p> <p>Emergency number kept by exit door.</p>

7. Temporary Closure Response

Priority	<p>Safety of staff, members of the community and/or site visitors.</p> <p>Staff must remain off-site until advised by the Fire Warden that the workplace is safe and available to be re-occupied and re-opened.</p>
Decision	<p>The Director shall make the final decision.</p>
Reporting the closure	<p>Notify Stakeholders and other office locations.</p> <p>Notify the local Radio Station.</p> <p>Notify staff.</p> <p>Notify community – if required</p>
Temporary Closure	<p>Prepare</p> <p>Engage the site’s Response Team.</p> <p>Prepare for Temporary Closure Plan with stakeholders</p> <p>Undertake required communications</p>

	<p>Respond</p> <p>Monitor the event and stay informed.</p> <p>Maintain communications with the Local Disaster Management Group LDMG</p> <p>Wait till safe to deploy to site for inspection.</p> <p>Inspect facilities/campus to identify damage. Report damage to Insurance Company.</p> <p>Assess staff status and support required.</p> <p>Engage Business Continuity Plan as required</p> <p>Undertake Suitability Assessment for decision to re-open or not.</p>
	<p>Recover</p> <p>Liaise with Insurance Company re repair schedule.</p> <p>Manage and support staff welfare issues.</p> <p>Monitor business continuity activities</p>
Re-opening	<p><i>Notify other locations and stakeholders.</i></p> <p><i>Advise staff.</i></p>
General principles	<p>'Safety before schedule' Normal routine should re-commence as soon as possible after the event and when safe to do so.</p>
Communications	<p>The Fire Warden informs stakeholders via the Communications Strategy using the established formats.</p>

8. Site Signage

 <input type="checkbox"/> Eye Wash Station <input type="checkbox"/> Deluge Shower	 <input type="checkbox"/> First Aid Kit	 <input type="checkbox"/> Fire Extinguisher <input type="checkbox"/> Fire Hose <input type="checkbox"/> Fire blanket	 <input type="checkbox"/> Spill Kit	 <input type="checkbox"/> Buoyancy Vest
 <input type="checkbox"/>	 <input type="checkbox"/>	 <input type="checkbox"/>	 <input type="checkbox"/>	 <input type="checkbox"/>
 <input type="checkbox"/>	 <input type="checkbox"/>	 <input type="checkbox"/>	 <input checked="" type="checkbox"/>	



9. Emergency Numbers

Display a copy of this list in prominent positions at the site.

Group	Contact/details	Phone number
Police	Life-threatening or time critical emergency	000 – calling from land line
	Non-life-threatening incident	131 444
	Local Police Station - Castle Hill Police Station	
Ambulance		000
Emergency Situations	Dial 000 and ask to speak to the relevant authority	000
Queensland Fire and Emergency Services	https://www.qfes.qld.gov.au	13 QGOV (13 74 68)
Qld State Emergency Service (SES)	https://www.ses.qld.gov.au/Pages/default.aspx	132 500
Hospital	[Insert Here]	[Insert Here]
Client Representative	[Insert Here]	[Insert Here]
QLD WorkCover	https://www.worksafe.qld.gov.au/	1300 362 128
Electrical Safety Office	https://www.electricalsafety.qld.gov.au	1300 362 128
Gas:		1800 427 532
Telstra	https://www.telstra.com.au	13 22 03
Environmental Protection Agency	https://environment.des.qld.gov.au	1300 130 372
Dial Before You Dig:	https://www.byda.com.au	1100 (DBYD Help Desk)
Ergon Energy:	https://www.ergon.com.au	13 22 96
Chief Warden	Andries van der Walt	0437 017 720
Wardens	Jonathan Aston	0472 729 916
First Aider	Andries van der Walt	0437 017 720
Project WHS Advisor (if applicable)	Tim Gillespie	0448 865 798
Regional Council	Hills Council	+61 2 9843 0555
Local Hospital	Lakeview Private Hospital	+61 2 8624 5000
Local Medical Centre	Kellyville Village Medical Centre	+61 2 8814 1555

10. Types of Training

10.1 Apply First Aid

Provides competencies required to recognise and respond to common life-threatening injuries or illnesses, including life-support using cardiopulmonary resuscitation (CPR), and to manage the casualty and incident until the arrival of medical or other assistance. In low-risk workplaces, first aiders are sufficiently trained if they can perform CPR and treat minor illnesses and injuries. A first aid certificate (within the last three years) and annual CPR refresher is required for first aid on-site.

10.2 Apply Advanced First Aid

Provides additional competencies required to apply advanced first aid procedures. This type of training is suitable for some high-risk workplaces.

10.3 Manage First Aid in the Workplace (Occupational First Aid)

Provides competencies required to apply advanced first aid procedures and to manage a first aid room.

10.4 Additional training for first aiders

First aiders should attend training on a regular basis to refresh their first aid knowledge and skills and to confirm their competence to provide first aid. Refresher training in CPR should be undertaken annually and first aid qualifications should be renewed every three years. First aiders may also need to undertake additional first aid training to respond to specific situations at their workplace. For example, where workers have severe allergies, first aiders should be trained to respond to anaphylaxis if this topic has not been covered in previous first aid training.

10.5 First Aid & Site Emergency Equipment Assessment

The minimum training and competency requirements to complete the below First Aid Kit and Site Emergency Equipment Assessment are as follows:

- HLTAID001-3 CPR Apply First Aid; and
- 3+ year’s experience in the construction industry; and
- Completion of OP07.3 Emergency Warden Training; or
- Completion of PUAWER005B Operate as part of an emergency control organisation.

Rohrig will ensure adequate first aid kits, additional modules, firefighting equipment, chemical spill kits and other emergency equipment is available. A Site First Aid Kit and Fire Extinguisher shall be located at the Site Supervisor’s Office; personal first aid kits are within each Rohrig employee’s vehicle.

10.5 ECO Training

Members of the ECO shall be trained in the emergency procedures and plans for the project. In addition, the minimum training requirements are mandatory:

- HLTAID001-3 CPR Apply First Aid; and
- 3+ year’s experience in the construction industry; and
- Completion of OP07.3 Emergency Warden Training; or
- Completion of PUAWER005B Operate as part of an emergency control organisation.

11. Emergency Equipment

The site must have readily available the correct equipment to effectively respond to emergency situations. Emergency equipment must be maintained through preventive maintenance procedures (inspection and testing) in accordance with the manufacturer’s recommendation to ensure that equipment is in ready condition for use. The inventory should be completed, and an inspection of emergency equipment shall be conducted on a three-monthly basis to ensure that equipment is available and functioning properly. The type of emergency equipment available on site should be reviewed periodically and form part of the 3 monthly review to reflect changing site conditions.

How to Visually Inspect Portable Fire Extinguishers - Ensure access to the extinguisher is not blocked and that the cabinet door, if applicable, opens easily. The cylinder pressure should be within the recommended level on extinguishers equipped with a gauge (as shown below). The needle should be in the green zone. It should be noted where an extinguisher needs replacing it is removed from service and stored in the site office until it is recharged.



Good



Needs replacing

Verify the locking pin is intact and the tamper seal is not broken and note any findings on the inspection report. Visually inspect the hose and nozzle to ensure they are in good condition and note any findings on the inspection report. Visually inspect the extinguisher for dents, leaks, rust, chemical deposits or other signs of abuse/wear and note any findings on the inspection report. If the extinguisher is damaged or needs recharging, note this on the action plan in the site inspection schedule. Portable fire extinguishers must be pressure tested (a process called hydrostatic testing) every six (6) years to ensure the cylinder is safe to use.

12. Emergency Response Requirements

The following checklist is to be completed to ensure that the provisions of First Aid facilities onsite are sufficient for the onsite activities. Location of the site and the location of supporting and available medical facilities are vital when determining first aid and emergency requirements. The following emergency response requirements have been assessed as applicable for this site:

Size & Location of Workplace		Number & Composition of Workers	
Number of floors:	4	Number of workers:	<150
Access between floors:	Stairs	Number of other persons:	Average - 3 visitors per day
Nearest Hospital:	3.6km	Nearest Medical Centre	700m
Maximum time to medical service:	10 minutes	Remote or isolated workers:	<input checked="" type="checkbox"/> No <input type="checkbox"/> Yes

Required First Aid Equipment & Facilities	
Number of Trained First Aiders:	Minimum of one per shift. At full production we will have at least 6 first aid members on site.
Training & Competencies for First Aiders:	Minimum Applied First Aid: Able to recognise and respond to common life-threatening injuries or illnesses; competent in CPR and other first aid procedures.
Number and location of first aid kits (The required kit must be identified by a competent person with First Aid Qualification)	One major incident response kit within First Aid office; First Aid Kit Required <input type="checkbox"/> Small First Aid Kit – Under 10 workers <input type="checkbox"/> Medium First Aid Kit – 10 to 50 workers <input checked="" type="checkbox"/> Large First Aid Kit – 50+ workers, Rohrig may likely issue two first aid kits if 50 and above workers.
First Aid Kit Contents & Modules:	<input checked="" type="checkbox"/> Standard Kit.
First Aid Kit Locations:	<input checked="" type="checkbox"/> First Aid Office
Kit Maintenance:	Tasked to Supervisor before Project commencement then every three months or following usage.
Additional emergency response equipment:	<input checked="" type="checkbox"/> Stretcher <input type="checkbox"/> Working at Height Rescue <input type="checkbox"/> Confined Space Retrieval <input type="checkbox"/> Other: <input type="checkbox"/> Alarm System <input checked="" type="checkbox"/> Two-way Radio <input type="checkbox"/> Satellite Phone <input checked="" type="checkbox"/> Other: Personal Mobile Phone used
Facilities:	<input checked="" type="checkbox"/> Medical Room (100+ Workers) <input type="checkbox"/> Ambulance <input type="checkbox"/> Care Flight <input type="checkbox"/> Deemed unnecessary
Fire Equipment types needed.	<input checked="" type="checkbox"/> Class A - Combustible materials <input checked="" type="checkbox"/> Class B - Flammable Liquids <input checked="" type="checkbox"/> Class C - Flammable Gases <input checked="" type="checkbox"/> Class D – Flammable Metals <input checked="" type="checkbox"/> Class E - Electrical

	<input checked="" type="checkbox"/> Fire Blanket 1 x 9kg ABE at Site Office 3 x 2kg Site Ute, Truck, Bobcat
Electrical	<input type="checkbox"/> LV Rescue Kit <input type="checkbox"/> Electrical Subcontractor have Qualification in Low Voltage Rescue & Provide CPR (HLTAID001 Provide cardiopulmonary resuscitation & UETDRRF06B Perform rescue from a live low voltage panel)
Substance SDS and Risk Assessments have been completed and are in the register	<input checked="" type="checkbox"/> Yes <input type="checkbox"/> No
Health Surveillance required?	Refer – to-Project Substance Register and Project Risk Register <input type="checkbox"/> Yes <input checked="" type="checkbox"/> No

13. Critical Incident Investigation

Refer to the Accident & Incident Investigation Procedure OP20.

Notifiable Incidents	Report to:	Timeframe
Serious incidents involving a death (fatality) or a serious injury or illness	OFSC – FSC Online, Qld Workcover - 1300 362 128, Client, Scheme Agent/Insurer	As soon as practicably possible
Other incidents involving an injury or illness where workers compensation is payable	Scheme Agent/Insurer	As soon as practicably possible Within 48 hrs.

14. Specific Emergency Response Requirements and Scenarios

Relevant to Project	Type	Emergency Response Procedure
<input type="checkbox"/>	Smoke, Fire or Explosion	Remain calm, clear and rational Approach situation with caution (and specifically look for evidence of spilt or leaking fuel, gas cylinders or other fuel sources or chemicals which could worsen the situation) If minor in nature (small smouldering object, minor fire, similar), you are trained to use an extinguisher, and a suitable extinguisher is available – extinguish the fire Where safe to do so, rescue persons from the immediate danger within the vicinity of the fire If not minor, or the fire is unsafe to extinguish, call 000 (or 112 from mobiles) – Ask for Fire / Emergency Services and notify Supervisor Evacuate all personnel well clear of the fire / explosion site and do not attempt to remove plant or other equipment Once Fire Services specialists have arrived and taken over, await further direction from emergency services workers Preserve and secure area for investigation, where necessary. Tip: If you are trapped in a fire, you may have to move through smoke. Smoke is a significant risk to health and life. If you can, place a wet cloth in front of your mouth and nose. If you feel you

		are becoming overwhelmed by smoke or fumes, get down on your hands and knees and keep your mouth low and approximately 5cm from the floor/ground.
<input type="checkbox"/>	Injury or Illness	<p>Remain calm, clear and rational</p> <p>Approach and assess patient/s</p> <p>If patient/s is/are in immediate danger and it is safe to do so, move them to a safer location (otherwise, do not move them)</p> <p>For minor injuries/illnesses, notify First Aider</p> <p>For serious injuries/illnesses, notify First Aider and call 000 (or 112 from mobiles) – Ask for Ambulance</p> <p>Send someone to wait for the ambulance, if able</p> <p>First Aider to obtain first aid kit</p> <p>First Aider to render first aid assistance and apply DRSABCD action plan where required (per diagram over page and training)</p> <p>Stay with the injured/ill person unless there is an immediate threat of danger</p> <p>Isolate the area from non-essential project personnel and members of the public</p> <p>Once Ambulance Paramedics have arrived and taken over, await further direction from emergency services workers and Supervisor</p> <p>Preserve and secure area for investigation, where necessary</p> <p>Obtain any witness/bystander contact details.</p>
<input type="checkbox"/>	Fatality	<p>Remain calm, clear and rational</p> <p>Approach situation with caution</p> <p>Call 000 (or 112 from mobiles) – Ask for Ambulance</p> <p>Notify Supervisor</p> <p>Isolate the area from non-essential project personnel and members of the public</p> <p>Lock down the site to restrict access from any person other than Emergency Services Personnel and authorised Rohrig / Client representatives</p> <p>Avoid contact with blood and other bodily fluids by wearing protective gloves</p> <p>If practicable, cover the body and make sure that it cannot be disturbed</p> <p>Preserve and secure area for investigation; do not interfere with any evidence</p> <p>Comfort any witnesses, bystanders or colleagues of the fatally injured worker/s</p> <p>Once Emergency Services Personnel have arrived and taken over, await further direction</p> <p>Obtain/collect factual information about the incident, if able.</p> <p>Note: Police will inform the fatally injured worker/s Next of Kin of the fatality. Post Incident Trauma Counselling will be offered to witnesses, bystanders, project personnel and the workers' colleagues</p>
<input type="checkbox"/>	Vehicle/Plant Breakdown, Crash or Rollover	<p>Remain clear, calm and rational</p> <p>Approach situation with caution (and specifically look for evidence of spilt or leaking fuel which could create a fire or explosion)</p> <p>Ensure that no open flame / ignition source is taken into the incident area.</p> <p>Notify Supervisor</p> <p>If any person is in immediate danger and it is safe to do so, rescue them and move them to a safer location (otherwise, do not move them)</p> <p>If any person is injured, initiate the 'injury, illness, fatality' emergency response procedure and comfort the person/s until help arrives</p> <p>If an injured person is pinned or crushed, take advice from a paramedic / medical specialist (as part of the initial request for emergency services) about how to release / remove the load and reassure them</p> <p>Once Emergency Services Personnel have arrived and taken over, await further direction</p> <p>Preserve and secure area for investigation, where necessary</p>
<input type="checkbox"/>	Adverse Weather, Including Floods	Remain calm, clear and rational

		<p>If time permits and safe to do so, secure external / loose items and materials to prevent them becoming airborne</p> <p>Close all doors and windows on windward side of buildings</p> <p>Open accessible windows on sheltered side (leeward) of buildings</p> <p>Move any people in the building to the sheltered side of buildings</p> <p>Do not use landline telephone during thunderstorms</p> <p>Listen to radio for storm updates</p> <p>Turn off and unplug all non-essential electrical equipment</p> <p>Leave when weather calms and it is safe to do so</p> <p>When leaving, beware of fallen power lines and trees, damaged buildings and flooded watercourses</p> <p>If in need of rescuing, notify Supervisor and call 000 (or 112 from mobiles) – Ask for Fire / Emergency Services or 13 25 00 for SES.</p>
□	Personal Threat (e.g. Assault)	<p>Remain calm, clear and rational</p> <p>Alert Supervisor or someone nearby to raise the alarm</p> <p>Be firm but polite with the assailant/s and let them know that their behaviour is not acceptable; do not however provoke the assailant/s or aggravate the situation</p> <p>Try to keep an exit at your back so that you can remove yourself from the situation</p> <p>If the behaviour of the person is such that outside intervention is required, call 000 (or 112 from mobiles) – Ask for Police</p> <p>If the victim/s is/are injured, initiate the ‘injury, illness, fatality’ emergency response procedure and comfort the person/s until help arrives</p> <p>Where able and it is safe to do so, isolate the victim/s from the assailant/s</p> <p>Isolate the area from non-essential project personnel and members of the public</p> <p>Where able, obtain and note details concerning the incident, including:</p> <p>Full name of victim/s</p> <p>Circumstances surrounding the assault</p> <p>Witness names and contact details</p> <p>Description/details of assailant/s</p> <p>Once Emergency Services Personnel have arrived and taken over, await further direction.</p> <p>Notes:</p> <p>Do not feel obliged to rectify/handle the situation on your own – ask for help where able.</p> <p>Assault, especially sexual assault is a very personal and traumatic crime for the victim, both physically and psychologically. It must be handled with the sensitivity and wellbeing of the victim foremost.</p>
□	Written Bomb Threat or Substance Threat	<p>Remain calm and quiet (to avoid any unnecessary angst)</p> <p>Put envelope/container down in a safe location; do not throw away any aspect of the envelope/package</p> <p>Avoid any further unnecessary handling</p> <p>Steps 2 and 3 are important so as to retain evidence, such as fingerprints, handwriting/type, paper and postmarks</p> <p>Notify Supervisor and call 000 (or 112 from mobiles) – Ask for Police</p> <p>Do not initiate an emergency evacuation unless instructed to by the Supervisor or Police.</p>
□	Suspicious Package	<p>Remain calm and quiet (to avoid any unnecessary angst)</p> <p>Apply HOT principle. An item is considered suspicious if it is HOT.</p> <ul style="list-style-type: none"> ○ Hidden: An unattended item that is intentionally hidden ○ Obviously Suspicious: An item with the characteristics of a bomb or hazardous material, e.g. suspicious labelling; leakage of fuel oil; unusual smells, bulges or protruding wires; power source; LED lights; pieces of metal or glass (shrapnel) ○ Not Typical: An item that would not typically be discarded or forgotten <p>If it is HOT, treat the package as a possible threat</p> <p>Secure the area</p>

		<p>Move away a safe distance</p> <p>Notify Supervisor and call 000 (or 112 from mobiles) – Ask for Police</p> <p>Once Emergency Services Personnel have arrived and taken over, await further direction.</p>
<input type="checkbox"/>	Phone Bomb Threat	<p>Remain calm, clear and rational (and try to not create any unnecessary angst)</p> <p>Do not hang up the phone</p> <p>Alert Supervisor or someone nearby to raise the alarm</p> <p>Write down details of the phone call on the Bomb Threat Checklist, (refer following page)</p> <p>Do not initiate an emergency evacuation unless instructed to by the Supervisor or Police.</p>
<input type="checkbox"/>	Internal emission or spill	<p>Call 000 for emergency services and seek and follow advice.</p> <p>Report the emergency immediately to the Fire Warden.</p> <p>Move staff away from the spill to a safe area and isolate the affected area.</p> <p>Seek advice in regard to clean up requirements, and if safe to do so, the spill can be cleaned up by staff. Personal Protective Equipment should be worn as per the requirements of the Material Safety Data Sheet and Safety Work Procedure.</p> <p>Contact stakeholders as required.</p>
<input type="checkbox"/>	Earthquake	<p>Call 000 for emergency services and seek and follow advice.</p> <p>Evacuate to assembly area/s.</p> <p>Check that all staff, visitors, and contractors are accounted for.</p> <p>Await ‘all clear’ advice from emergency services or further advice before resuming normal workplace activities.</p> <p>Contact stakeholders as required.</p>
<input type="checkbox"/>	Work at Height / Fall Arrest Rescue	<p>Implement activity specific rescue / retrieval plan where one has been prepared for the task.</p> <p>Remain calm, clear and rational</p> <p>Communicate with fallen person (if possible) to gauge severity of the incident and injuries</p> <p>If safe to do so, encourage the fallen person to self-rescue / climb to safety / equivalent</p> <p>If a fallen person is unconscious or suspended at heights, immediate action must be taken to reach the person in a safe manner and remove pressure of the harness system (via competent operation of EWP, telehandler, loader or crane with workbox, for example)</p> <p>Notify Supervisor and call 000 (or 112 from mobiles) – Ask for Ambulance / Specialist Height Rescue Team</p> <p>Where safe to do so, initiate work at height retrieval / rescue via trained height rescue personnel on site (rescuers must remain attached and not place themselves at risk of a fall)</p> <p>Take weight out of the harness as soon as practicable and per Paramedic / Height Rescue Specialist advice</p> <p>Once retrieval / rescue has been performed, follow ‘injury, illness, fatality’ emergency response procedure</p>
<input type="checkbox"/>	Gas or Chemical	<p>Gas and Chemical hazards can occur either within Rohrig’s premises or on-site workplaces, or from adjoining properties depending on the severity and wind direction.</p> <p>Given the small quantities of chemicals used by Rohrig (mainly confined to adhesives, solvents, paint, cement, cold mix asphalt and flammable fuels) it is highly unlikely that an emergency will occur that impacts on employees or subcontractors other than the person using the chemical.</p> <p>Where gas emissions are evident or suspected, electrical equipment is not to be switched on or turned-off, as the switching may spark and become a source of ignition.</p> <p>The person encountering the hazard shall do the following:</p> <p>Call 000 for emergency services and seek and follow advice.</p> <p>Evacuate to assembly area/s.</p> <p>Check that all staff, visitors, and contractors are accounted for.</p> <p>Await ‘all clear’ advice from emergency services or further advice before resuming normal workplace activities.</p> <p>Contact stakeholders as required.</p>

<input type="checkbox"/>	<p>Chemical Spill or Waterway Contamination</p>	<p>Remain calm, clear and rational</p> <p>If safe and easy to do so, isolate / shut off valves that could restrict any further spillage</p> <p>If a minor spill, and the chemical / agent is known – access and follow SDS instructions for spill clean-up</p> <p>If a major spill and/or personnel are feeling ill / suffering from the chemical or related fume / vapour / gas – if safe to do so, take immediate action to remove personnel from the area and evacuate others in close proximity</p> <p>Notify Supervisor and call 000 (or 112 from mobiles) – Ask for Chemical Response Unit / Ambulance as necessary</p> <p>Do not attempt to wash / clean / clear the chemical without consulting the SDS and Chemical Response Unit specialists</p> <p>If the spill involves contaminated water or similar and if safe to do so, attempt to sand-bag / redirect / buffer the water from drains, waterways or sensitive locations.</p>
<input type="checkbox"/>	<p>Confined Space</p>	<p>Implement activity specific rescue / retrieval plan where one has been prepared for the task.</p> <p>Remain calm, clear and rational</p> <p>Communicate with injured person (if possible) to gauge severity of the incident and injuries</p> <p>If safe to do so, encourage the injured person to self-rescue / exit the space / equivalent</p> <p>If an injured person is unconscious or seriously injured in the space immediate planning by a competent confined space person must be undertaken prior to entering the space (inclusive of checks to verify safe air quality, and to continuously verify safe air quality once the entry commences)</p> <p>Notify Supervisor and call 000 (or 112 from mobiles) – Ask for Ambulance / Specialist Height / Confined Space Rescue Team</p> <p>Where safe to do so, initiate confined space rescue via trained confined space entry personnel on site (rescuers must confirm ongoing air quality at all times and not place themselves at risk of an unsafe atmosphere or engulfment)</p> <p>A rescue involving a compromised air quality location must only be attempted by fully trained confined space rescue personnel who have the adequate self-contained breathing apparatus to ensure their own personal safety</p> <p>Once rescue has been performed, follow ‘injury, illness, fatality’ emergency response procedure.</p>
<input type="checkbox"/>	<p>Medical Emergency Procedure</p>	<p>Raise the alarm.</p> <p>Do not move the individual unless it is essential to protect life.</p> <p>Call for Fire Warden / First Aid Officer</p> <p>Assist First Aid Officer with immediate treatment.</p> <p>Control any heavy bleeding using direct pressure on the wound,</p> <p>If necessary, to prevent shock, keep the individual warm and elevate lower extremities if possible.</p> <p>Limit incident attendance to essential personnel</p>
<input type="checkbox"/>	<p>Specific First Aid Procedures: Snake Bite, Electric Shock, Eye Injury</p>	<p>If you are unlucky enough to be bitten, here is what you should and should not do. Assume ALL snakes are venomous, and take the following action:</p> <ul style="list-style-type: none"> Do not panic. Try to remain calm, lie down and immobilise the bitten area. It is unlikely that the bite will be life-threatening. Apply a bandage but do not block circulation. Take a broad bandage and bind along the limb starting at the bite area, at the same pressure as for a sprain. Then bandage down the limb and continue back up the entire limb over and above the bite area. This will help prevent the spread of the venom through the body. Do not remove the bandage. It is often easier to go over the top of clothing such as jeans rather than remove clothing. In an emergency, strips of clothing or pantyhose can be used instead of a bandage. Immobilise the limb with a splint. Lie down and keep the limb completely still until help arrives. Do not elevate the limb or attempt to walk or run. Movement will encourage the spread of the venom through the body. <p>Do not attempt to catch the snake. All too often, the snake will bite again if an attempt is made to catch it. Identification of the snake species can be obtained through samples of the patient's</p>

		<p>blood or urine, and from venom around the bite area. If the species of snake still remains uncertain, a poly-antivenin may be used, which is suitable for treatment of all venomous snake bites.</p> <p>Do not wash the wound. Venom left on the skin will help doctors identify the snake and administer the appropriate antivenin.</p> <p>Do not cut the wound. This will spread the venom into the bloodstream and can cause more serious injuries than the snake bite itself.</p> <p>Seek medical help. An antivenin may be required.</p>
□	Client Requirements and Neighbour Emergencies	<p>The Client and any neighbouring businesses must be consulted to ensure adequate interface with their emergency evacuation plans and requirements. Emergencies experienced by neighbouring business have the potential to impact upon site emergency management measures. Examples where interface with neighbouring business and properties is critical include:</p> <ul style="list-style-type: none"> • chemicals used in production processes. • high volumes of public use such as shopping centres or cinemas • hospitals and schools • properties containing asbestos. <p>Neighbouring properties including private residences should be advised in advance of emergency drills or training exercises scheduled to be conducted. Conversely, neighbouring businesses should advise the project of any drills and exercises that they will be conducting so that the project can interface and respond appropriately.</p>
□	Structural Collapse (Formwork / Scaffold)	<p>Remain calm, clear and rational</p> <p>Stop all works surrounding the area or above the area and evacuate all workers and/or building occupants aside from those involved in the response</p> <p>If a person is injured / trapped - communicate with the injured person (if possible) to gauge severity of the incident and injuries</p> <p>If safe to do so, encourage the injured person to self-rescue / exit the location in a slow manner</p> <p>Do not enter area or move plant into an at risk / compromised location where this could cause further structural collapse or a fall from height</p> <p>Notify Supervisor and call 000 (or 112 from mobiles) – Ask for Fire / Emergency Services / Specialist Height Rescue Team</p> <p>Follow external services direction and do not re-enter the site until specialist engineering advice and controls have been implemented.</p>
□	Excavation / Trench Collapse	<p>Remain calm, clear and rational</p> <p>Direct powered mobile plant / vehicles in the vicinity to stop work</p> <p>Communicate with trapped person (if possible) to gauge severity of the incident and injuries</p> <p>If safe to do so, encourage the trapped person to self-rescue / dig to safety and immediately assist them to do so via hand digging / careful use of hand tools only</p> <p>If a trapped person is unconscious or fully buried immediate action must be taken to reach the person in a safe manner and remove soil and pressure (via hand digging and careful use of hand tools only</p> <p>Notify Supervisor and call 000 (or 112 from mobiles) – Ask for Ambulance</p> <p>Plant / equipment must not be used / placed in a position that could add pressure to the trapped person or cause additional trench collapse</p> <p>Personnel attempting to dig out trapped person must not put themselves at risk of being trapped in the trench themselves</p> <p>Where a person has been pinned or crushed, take advice from a paramedic / medical specialist (as part of the initial request for emergency services) about how to release / remove the load</p> <p>Once retrieval has been performed, follow 'injury, illness, fatality' emergency response procedure.</p>
□	Electrical Shock / Arc Incident	<p>Remain calm, clear and rational</p> <p>Do not contact an injured or shocked person (as you too could receive an electric shock)</p>

		<p>If safe to do so – isolate the electrical energy source that is powering the equipment / injured person</p> <p>If known low voltage and competent to do so – initiate a live low voltage rescue of the person via live low voltage rescue kit or equivalent equipment</p> <p>If high voltage or situation is unsafe – seek licensed electrical worker assistance as soon as possible</p> <p>Notify Supervisor and call 000 (or 112 from mobiles) – Ask for Ambulance</p> <p>Follow ‘injury, illness, fatality’ emergency response procedure</p> <p>Ensure any person who received an electrical shock attends specialist medical attention so that safe heart function can be monitored and confirmed.</p>
□	Contact with Live Overhead or Underground Services	<p>Remain calm, clear and rational</p> <p>Stop all work activities within the immediate area</p> <p>Notify Supervisor</p> <p>Where safe to do so, make immediate area safe</p> <p>Where requested to do so by Supervisor, initiate emergency evacuation (e.g. sound air horn, communicate the situation via UHF radio)</p> <p>If live electricity has been contacted by an item of powered mobile plant, advise operator to remain inside the cabin</p> <p>If safe to do so, powered mobile plant operator is to operate the plant to remove contacting part from the service, and move the plant well clear of the service</p> <p>Isolate the area from non-essential project personnel and members of the public and ensure no ignition sources are created if a gas service has been compromised</p> <p>Supervisor to coordinate an isolation of the service (e.g. electrical, water, gas, similar) via competent on-site personnel if safe to do so</p> <p>Supervisor to coordinate an isolation of the services via the external Asset Owner</p> <p>If worker is injured, initiate the ‘injury, illness, fatality’ emergency response procedure and comfort the worker until help arrives</p> <p>Notify Asset Owner if damage to overhead or underground services has occurred.</p>
□	Asbestos / Contaminated Release	<p>Remain calm, clear and rational</p> <p>Stop all work activities within the immediate area</p> <p>Notify Supervisor</p> <p>Isolate the area from non-essential project personnel and members of the public</p> <p>Supervisor to seek Rohrig WHS input and external occupational hygienist input to organise necessary sampling / monitoring; factual communication with involved parties; advise on external WHS Regulator notification requirements; and containment and clean-up requirements.</p>
□	Evacuation, Lock Down or Lock Out	<p>Remain calm, clear and rational (and align with an client / school specific requirements)</p> <p>Follow / consider ‘bomb / personal threat or suspicious package’ emergency procedure, if relevant</p> <p>Where requested to do so by Supervisor, initiate emergency evacuation (e.g. sound air horn, communicate the situation via UHF radio, use loud speaker, or initiate evacuation tone)</p> <p>Communicate clearly and calmly</p> <p>As relevant to the situation – provide direction as to what is required and provide short clear commands:</p> <p>Evacuation requirements</p> <p>Stay in place / lock down requirements</p> <p>Exclusion / lock out requirements</p> <p>Provide support to personnel who require assistance</p> <p>Ensure personnel are as comfortable as practicable at the location they are in</p> <p>Communicate regular clear updates to personnel until the emergency situation is confirmed as being over / resolved.</p>

15. Emergency Plan Checklist

Emergency Plan Checklist	YES	NO
<p>Responsibilities</p> <ul style="list-style-type: none"> • Has someone with appropriate skills been made responsible for specific actions in an emergency, for example managing an evacuation, calling emergency services, exclusion zones, excluding non-essential personnel from the emergency area? • Is someone responsible for making sure all workers and others in the workplace, for example contractors, customers and visitors are accounted for in an evacuation? • Is someone responsible for managing access to the site and reps from the media? • Do workers working alone know what to do in an emergency? • Are specific procedures in place for critical functions, for example power shut-downs? 		
<p>Emergency contact details</p> <ul style="list-style-type: none"> • Are emergency contact details relevant to the types of possible emergencies, for example fire brigade, police and poison information centre? • Are the emergency contact details displayed at the workplace in an easily accessible location? • Are contact details updated regularly? 		
<p>Evacuations</p> <ul style="list-style-type: none"> • Have all emergencies requiring an evacuation at the workplace been identified? • Has an evacuation procedure been prepared? • Does the EMP: <ul style="list-style-type: none"> ○ address all types of situations and hazards which may arise at the workplace ○ cover everyone who may be present at the workplace ○ allow for quick and safe evacuation when needed, particularly formwork and prop areas ○ -allow for crane operator rescue ○ clearly identify escape routes to safe assembly areas ○ include a process for accounting for persons • Is the evacuation procedure clearly and prominently displayed at the workplace including access to multiple levels? • Is there a mechanism, for example an alarm siren for alerting staff of an emergency? <ul style="list-style-type: none"> ○ If yes, is it regularly tested to ensure its effectiveness? • Is there a documented site plan that illustrates the location of first aid and fire protection equipment, emergency exits and assembly points? <ul style="list-style-type: none"> ○ If yes, is it posted in key locations throughout the workplace? • Are all exits, corridors and aisles readily accessible and kept clear of obstructions? • Does the workplace have illuminated exit signs where required? 		
<p>Fire protection equipment</p> <ul style="list-style-type: none"> ▪ Has a fire risk assessment been conducted? • Does the workplace have appropriate fire protection equipment? • Is it suitable for the types of risks at the workplace, for example foam or dry powder type extinguishers for fires that involve flammable liquids? • Is it properly maintained and regularly checked and tested by the local fire authority or fire equipment supplier? • Is the area where the equipment is stored kept clear of obstructions? • Are adequate numbers of workers trained to use fire extinguishers? • Do they know what type of extinguisher to use for different types of fires? 		
<p>Extreme weather conditions</p> <ul style="list-style-type: none"> • If there is a risk of extreme or dangerous weather conditions, for example bushfire, floods or storms, will the control measures be effective in these conditions? • Do procedures accommodate declarations of extreme weather warnings? Examples of extreme weather warnings may include warnings such as cyclone warnings. 		
<p>Chemical safety</p> <ul style="list-style-type: none"> • Are current safety data sheets available for all hazardous chemicals on site? • Are all hazardous chemicals labelled and stored in a safe manner? • Is appropriate equipment available to initially respond to a chemical incident, for example absorbent material to contain a liquid spill? 		
<p>First aid</p> <ul style="list-style-type: none"> • Has a first aid risk assessment been conducted? • Does the workplace have trained first aiders and suitable first aid facilities? • Are workers aware of where first aid facilities are kept and who first aiders are? 		
<p>Neighbouring businesses</p> <ul style="list-style-type: none"> • Have neighbouring businesses been considered if an emergency occurs? 		

<ul style="list-style-type: none"> • How would they be advised of an emergency situation arises (if applicable)? • Should they be consulted about the preparation and coordination of emergency plans? • Have the risks from neighbouring businesses been considered • Have onsite and off-site vehicle accidents been considered? 		
<p>Post incident follow-up</p> <ul style="list-style-type: none"> • Are there procedures in place to notify the relevant regulator about a notifiable incident where necessary? • Are there procedures in place to ensure the cause of the emergency is determined and action is taken to prevent a similar incident occurring again? • Are there procedures in place to ensure the welfare of workers after an emergency or an incident, for example medical treatment or trauma counselling? 		
<p>Monitoring and Review</p> <ul style="list-style-type: none"> • Are practice drills scheduled to assess the effectiveness of the EMP? • Are drills scheduled to meet varying conditions i.e. early works, structural, finishing works? • Is someone responsible for documenting and retaining the results of emergency plan practice runs? • Is a process in place for monitoring and reviewing the EMP and informing workers of any revisions? 		

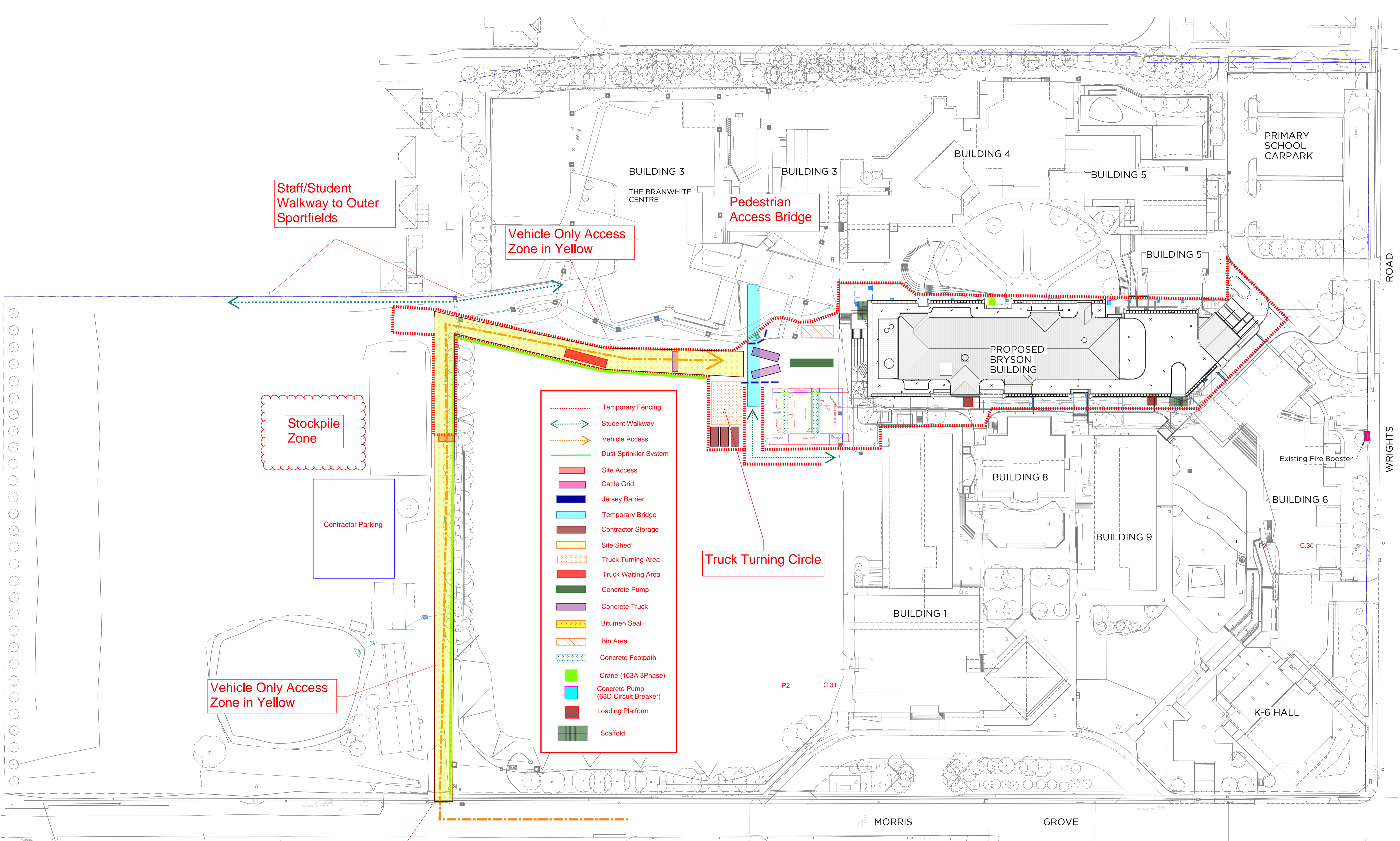

Staff/Student Walkway to Outer Sportfields

Vehicle Only Access Zone in Yellow

Pedestrian Access Bridge

Stockpile Zone

Contractor Parking

Vehicle Only Access Zone in Yellow

Truck Turning Circle

No Pedestrian Access beyond Gate 14

- - - - - Temporary Fencing
- - - - - Student Walkway
- - - - - Vehicle Access
- Dust Sprinkler System
- Site Access
- Cattle Grid
- Jersey Barrier
- Temporary Bridge
- Contractor Storage
- Site Shed
- Truck Turning Area
- Truck Waiting Area
- Concrete Pump
- Concrete Truck
- Bitumen Seal
- Bin Area
- Concrete Footpath
- Crane (163A 3Phase)
- Concrete Pump (63D Circuit Breaker)
- Loading Platform
- Scaffold

Scale 1:500

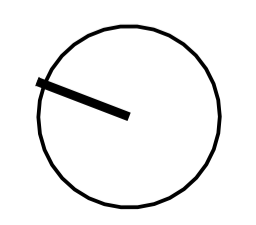

A	05/04/24	Issue for Tender
P6	22/03/24	For Client's Approval
P5	02/02/24	Issue for Consultants
P4	28/11/23	Issue for 50% Costing
ISSUE	DATE	REVISION

DO NOT SCALE FROM DRAWING. USE FIGURED DIMENSION ONLY. CHECK ALL DIMENSIONS ON SITE BEFORE MANUFACTURE OR CONSTRUCTION.	
PROJECT	William Clarke College
CLIENT	William Clarke College
DWG	Site Plan
CLIENT REF & CONTACT	1 Morris Grove, Kellyville
DATE	Issue Date
SCALE	A1 : 500
PROJECT #	3015
DWG #	A0101
REVISION	A

PMDL ARCHITECTURE INTERIORS MASTERPLANNING

pmdl.com.au

PMDL ARCHITECTURE + DESIGN PTY LTD ABN 56 060 980 337
NEW NOMINATED ARCHITECTS: ANDREW PENDER 337 DAVID MORRIS 5865 VICKI VAN DUJK 9476